



Do More.®



CHAMPION  
**HAZ-DUCT®**



ISO 9001:2008 CERTIFIED

**Champion Fiberglass, Inc. is the leading manufacturer of fiberglass conduit, Haz Duct and bridge hangers for electrical and mechanical markets.**

Champion Fiberglass began production of epoxy fiberglass conduit and fittings in 1988. The company has the most advanced production facilities for manufacturing fiberglass conduit in North America. A well-trained and highly efficient work force utilizes proprietary high-speed winding equipment and high temperature curing ovens to ensure consistent production standards to produce the highest quality fiberglass conduit on the market.

In 1989, Champion Fiberglass developed the first conduit from epoxy resins that had flame resistance and low smoke characteristics, meeting the most stringent codes and specifications. Today this conduit system has been integrated into the **CHAMPION DUCT®** system and is **UL** and **CSA listed** for both below and above ground use.

Another milestone evolved in 2006 when Champion Fiberglass completed development of a Phenolic Conduit System, **FLAME SHIELD®**. It is now the number one choice conduit for subways, including tunnels and stations. **FLAME SHIELD** conforms to the **NFPA 130** requirements, including the 2010 edition.

In 2008, **CHAMPION HAZ DUCT®** (XW Type fiberglass conduit) was allowed for use in **Class I Div 2** installations, per the **National Electrical Code (NEC)**. This was accomplished by Champion Fiberglass after having worked with UL and NEC on this issue for many years.

Champion Fiberglass is an **ISO 9001:2008 Certified Company**. We offer our customers innovative solutions with the highest quality products and customer service available in our industry. Our headquarters and manufacturing are located in Spring, Texas.



# CONTENTS

---

<b>Features and Advantages</b> .....	4-5
<b>Joining System / Expansion Joints per NEC</b> .....	6
<b>Field Bending</b> .....	7
<b>Straight Section</b> .....	8
<b>Fittings</b> .....	9-14
<b>Elbows</b> .....	15-19
<b>Accessories / Epoxy Adhesives</b> .....	20-21
<b>Support Systems</b> .....	22
<b>Engineering Information</b> .....	23-24
<b>Corrosion Resistance Guide</b> .....	25-28
<b>Corrosion Resistance Guide</b> .....	29
<b>Sealing Fittings (Class I Div 1 to Class I Div 2)</b> .....	30
<b>NEC Code - Sealing Fittings (Class I Div 1 to Class I Div 2)</b> .....	31-32
<b>National Electrical Code, NEC (2008)</b> .....	33
<b>Limited Warranty</b> .....	34



CHAMPION  
**HAZ DUCT<sup>®</sup>**

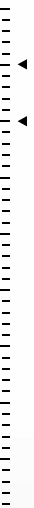

# FEATURES & ADVANTAGES

	Epoxy Fiberglass XW	PVC Sch 80	Galvanized Rigid Steel	PVC Coated Steel	Aluminum
<b>Cable Fault</b> Fiberglass conduit will not melt or weld the wire to the inside of the conduit under fault conditions as can happen with PVC, steel and aluminum conduit.	Not Affected	Melt/ Fuse	Weld	Weld	Weld
<b>Corrosion Resistance</b> Fiberglass conduit has the broadest range of corrosion resistance of all of these conduit materials. See page 29 for further information.	Wide Range	Limited	Poor	Limited	Limited
<b>Toxicity/Halogens</b> Fiberglass conduit does not release toxic halogens (i.e. chlorine and bromine) when burning.	No	Yes	No	Yes	No
<b>Weight Comparison</b> (lbs. per 100 ft., approx.) Fiberglass conduit offers the lowest weight and is still very rigid.	¾" 61 1" 68 1¼" 82 1½" 118 2" 126 ½" 154 3" 182 3½" 210 4" 238 5" 294 6" 350	29 43 59 99 99 152 212 262 310 431 592	105 153 201 246 334 527 690 831 982 1344 1770	105 153 201 246 334 527 690 831 982 1344 1770	36 53 70 86 116 183 239 288 340 465 612
<b>Support Spacing for 4" Conduit (ft)</b>	7	7	10	10	10
<b>Temperature Range (°F)</b> Fiberglass has an excellent wide temperature range.	-60° to +250°	+40° to +150°	N/A	N/A	N/A
<b>Handling in Low Temperatures</b> Fiberglass conduit has been shown to retain its properties at low temperatures allowing year round installations.	Excellent	Brittle	Excellent	Excellent	Excellent
<b>Burn Through (Cable Pull)</b> Fiberglass conduit is an excellent material for avoiding "burn through" when pulling cable.	No	Yes	No	No	No

	Epoxy Fiberglass XW	PVC Sch 80	Galvanized Rigid Steel	PVC Coated Steel	Aluminum
<b>Coefficient of Friction Using PVC Jacketed Cable</b> Fiberglass conduit offers one of the lowest coefficient of friction available today for conduit systems. It is completely resistant to any of the current pulling lubricants corrosive properties.	0.38	0.90	0.55	0.55	0.25
<b>Conductivity</b> Fiberglass conduit acts as an excellent insulator.	No	No	Yes	Yes	Yes
<b>UV Stable (w Resistance)</b> (Per UL 1684 & CSA-C22.2 No. 211.3-96)	Good	Poor	Excellent	Poor	Excellent
<b>Coefficient of Thermal Expansion</b> (10 <sup>-5</sup> inch/inch/°F) *The coefficient is 3.5 for the PVC layer. Because of the broad difference between the two materials, adhesion is severely affected during temperature contraction and expansion.	1.0	3.5	0.7	3.5*	3.5
<b>Distance Between Expansion Joints (ft)</b>	200	50	200	200	50
<b>Resistance to Rodents &amp; Fire Ants</b> Fiberglass conduit is extremely resistant to attack from rodents as well as to the aggressive chemicals secreted by fire ants.	Excellent	Poor	Excellent	Excellent	Excellent
<b>Field Handling</b> Due to its light weight, ease of cutting and integral bell, fiberglass conduit is very easy to install.	Excellent	Good	Very Poor	Very Poor	Poor
<b>Memory</b> Fiberglass conduit will retain its original shape after impact or compression.	Yes	No	No	No	No

## ADHESIVE JOINT

The adhesive joint is the straight socket joint combined with epoxy adhesive. The adhesive is applied to the spigot end of the conduit, and after the proper set up time, the joint is as strong as the conduit itself. This type of joining method provides the best water tightness and pull out strength. For pull out strength, see page 26.

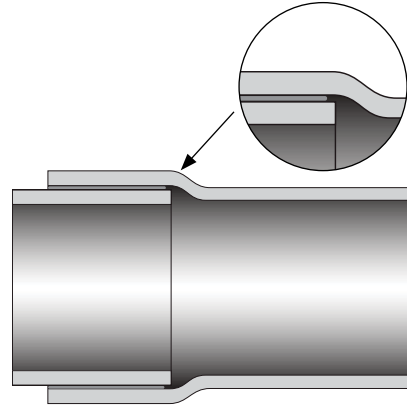

## EXPANSION JOINTS PER NEC

NEC 2008 Article 355.44 Expansion Fittings. "Expansion fittings for RTRC shall be provided to compensate for thermal expansion and contraction where the length change, in accordance with Tables 355.44, is expected to be 6 mm (¼ in.) or greater in a straight run between securely mounted items such as boxes, cabinets, elbows, or other conduit terminations."

**Table 355.44(B) Expansion Characteristics of Reinforced Thermosetting Resin Conduit (RTRC)**  
**Coefficient of Thermal Expansion =  $1.5 \times 10^{-5}$  in/in/°F ( $2.7 \times 10^{-5}$  mm/mm/°C)**

Temperature Change (°F)	Length Change of RTRC Conduit (in/100 ft)	Temperature Change (°F)	Length Change of RTRC Conduit (in/100 ft)	Temperature Change (°C)	Length Change of RTRC Conduit (mm/m)
5	0.09	105	1.89	5	0.14
10	0.18	110	1.98	10	0.27
15	0.27	115	2.07	15	0.41
20	0.36	120	2.16	20	0.54
25	0.45	125	2.25	25	0.68
30	0.54	130	2.34	30	0.81
35	0.63	135	2.43	35	0.95
40	0.72	140	2.52	40	1.08
45	0.81	145	2.61	45	1.22
50	0.90	150	2.70	50	1.35
55	0.99	155	2.79	55	1.49
60	1.08	160	2.88	60	1.62
65	1.17	165	2.97	65	1.76
70	1.26	170	3.06	70	1.89
75	1.35	175	3.15	75	2.03
80	1.44	180	3.24	80	2.16
85	1.53	185	3.33	85	2.30
90	1.62	190	3.42	90	2.43
95	1.71	195	3.51	95	2.57
100	1.80	200	3.60	100	2.70

## FIELD BENDING

Fiberglass conduit is field bendable/workable in sizes ¼" - 2½" to a 90° angle with a 9" or larger radius. Bending fiberglass conduit in the field should be done when offsets are required and factory bends are not on site. It is not recommended that the installer purchase straight sections of conduit with the intent of doing all of the bends in the field. Field bending of fiberglass conduit is recommended only when absolutely necessary. The process takes time to do right and should not be rushed in order to get the proper results. It is recommended that bends be calculated in the take-off and ordered with the straight sections.

Field bending is governed by **Article 355** in the **2008 NEC: Bends - How They Are Made**. Bends shall be made so that the conduit will not be damaged and the internal diameter of the conduit will not be effectively reduced. Field bends shall be made only with bending equipment identified for the purpose. The radius of the curve to the centerline of such bends shall not be less than shown in **2008 NEC, Chapter 9 Table 2**.

**2008 NEC, Chapter 9: Table 2 Radius of Conduit and Tubing Bends**

Size of Conduit		Other Bends	
Metric Designator	Trade Size	mm	in.
16	½	101.6	4
21	¾	127	5
27	1	152.4	6
35	1¼	203.2	8
41	1½	254	10
53	2	304.8	12
63	2½	381	15
78	3	457.2	18
91	3½	533.4	21
103	4	609.6	24
129	5	762	30
155	6	914.4	36

If field bending is required, the process is relatively simple. The conduit is heated in a standard PVC hot box. The heating time ranges from approximately 20 seconds to 60 seconds depending on the temperature of the hot box and the size of the conduit.

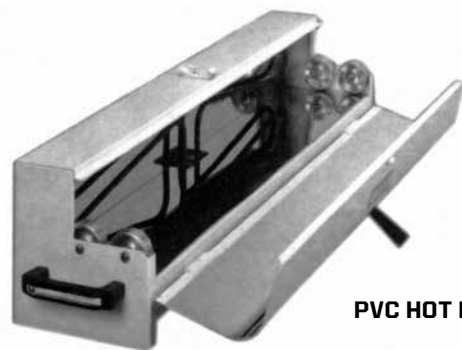

**PVC HOT BOX**

After heating, immediately place conduit in bending jig and begin to bend. It is extremely important that a jig/form is used to bend the conduit to avoid kinking. When installing field bent fiberglass conduit, it is best to install the elbow or offset immediately and support it by using a conduit strap on both ends of the bend.

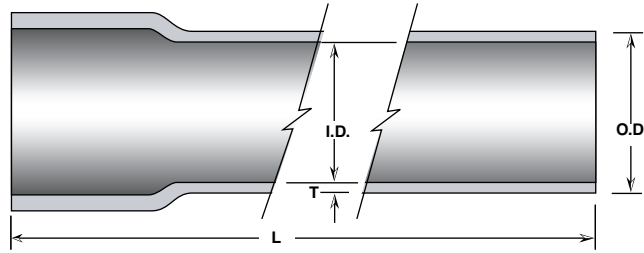

## STRAIGHT SOCKET (XW)

Type XW (Xtra Wall) Inches (Metric)									
Nominal Size	Item No. Aboveground	UL Listed	Outside Diameter		Min. Inside Diameter	Nominal Wall Thickness* (T)	Length (L)	Weight	
			Average	Tolerance				lbs/ft	kg/m
¾ (19)	07C-XW-10S	Yes	1.410 (36)	+0.056 (1.4) -0.036 (0.9)	0.910 (23)	.25 (6)	10 ft (3m)	.61 (0.91)	
1 (25)	10C-XW-10S	Yes	1.675 (43)	+0.056 (1.4) -0.036 (0.9)	1.175 (30)	.25 (6)	10 ft (3m)	.68 (1.01)	
1¼ (32)	12C-XW-20-S	Yes	2.020 (51)	+0.056 (1.4) -0.036 (0.9)	1.520 (39)	.25 (6)	20 ft (6.1m)	.82 (1.22)	
1½ (38)	15C-XW-20-S	Yes	2.260 (57)	+0.056 (1.4) -0.036 (0.9)	1.760 (45)	.25 (6)	20 ft (6.1m)	1.18 (1.76)	
2 (51)	20D-XW-20-S	Yes	2.500 (64)	+0.056 (1.4) -0.036 (0.9)	2.000 (51)	.25 (6)	20 ft (6.1m)	1.26 (1.88)	
2½ (64)	25D-XW-20-S	Yes	3.000 (76)	+0.056 (1.4) -0.036 (0.9)	2.500 (64)	.25 (6)	20 ft (6.1m)	1.54 (2.29)	
3 (76)	30D-XW-20-S	Yes	3.500 (89)	+0.056 (1.4) -0.036 (0.9)	3.000 (76)	.25 (6)	20 ft (6.1m)	1.82 (2.71)	
3½ (89)	35D-XW-20-S	Yes	4.000 (102)	-0.036 (1.4) +0.056 (0.9)	3.500 (89)	.25 (6)	20 ft (6.1m)	2.10 (3.13)	
4 (102)	40D-XW-20-S	Yes	4.500 (114)	+0.056 (1.4) -0.036 (0.9)	4.000 (102)	.25 (6)	20 ft (6.1m)	2.38 (3.54)	
5 (127)	50D-XW-20-S	Yes	5.500 (140)	+0.056 (1.4) -0.036 (0.9)	5.000 (127)	.25 (6)	20 ft (6.1m)	2.94 (4.38)	
6 (152)	60D-XW-20-S	Yes	6.500 (165)	+0.056 (1.4) -0.036 (0.9)	6.000 (152)	.25 (6)	20 ft (6.1m)	3.50 (5.21)	
8** (203)	80C-XW-20-S	--	8.900 (226)	+0.056 (1.4) -0.036 (0.9)	8.400 (213)	.25 (6)	20 ft (6.1m)	4.80 (7.14)	
10 (254)	100D-XW-20-S	--	10.500 (267)	+0.056 (1.4) -0.036 (0.9)	10.000 (254)	.25 (6)	20 ft (6.1m)	5.74 (8.54)	
12 (305)	120D-XW-20-S	--	12.500 (318)	+0.056 (1.4) -0.036 (0.9)	12.000 (305)	.25 (6)	20 ft (6.1m)	6.86 (10.21)	

\* Actual wall thickness is that required to meet the performance requirements for specifications. Other wall thicknesses are available by special request.

\*\* XW type conduit is also available with an inside diameter of 8.000 (203). Please contact our factory for further information.

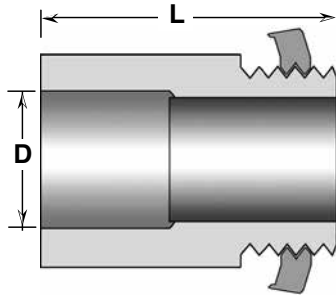

### BOX CONNECTOR

[Straight Threads]

A box connector creates a separable termination into a box. This connector has straight threads (NPS) and is supplied with a locknut, O-ring supplied upon request.

Nominal Size	Type	Item No.	D		Weight			
			lbs	kg				
¾	XW	07C-XW-30	1.435	(36)	3	(76)	0.11	(0.05)
1	XW	10C-XW-30	1.700	(43)	3	(76)	0.22	(0.10)
1¼	XW	12C-XW-30	2.045	(52)	3	(76)	0.35	(0.16)
1½	XW	15C-XW-30	2.285	(58)	3	(76)	0.49	(0.22)
2	XW	20D-XW-30	2.520	(64)	5	(127)	0.85	(0.39)
2½	XW	25D-XW-30	3.025	(77)	5	(127)	0.94	(0.43)
3	XW	30D-XW-30	3.520	(89)	5	(127)	1.28	(0.58)
3½	XW	35D-XW-30	4.025	(102)	5	(127)	1.77	(0.80)
4	XW	40D-XW-30	4.520	(115)	7	(178)	2.09	(0.95)
5	XW	50D-XW-30	5.520	(140)	7	(178)	2.75	(1.25)
6	XW	60D-XW-30	6.520	(166)	7	(178)	2.97	(1.35)

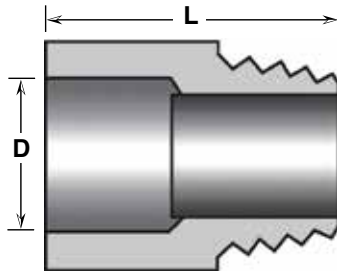

### MALE ADAPTER

[Tapered Threads]

Male adapters with tapered threads (NPT) are generally used for joining to female threads of rigid steel, Myers type hubs or terminating into precast iron boxes with female thread entrances.

Nominal Size	Type	Item No.	D		Weight			
			lbs	kg				
¾	XW	07C-XW-33	1.435	(36)	3	(76)	0.09	(0.04)
1	XW	10C-XW-33	1.700	(43)	3	(76)	0.19	(0.09)
1¼	XW	12C-XW-33	2.045	(52)	3	(76)	0.24	(0.11)
1½	XW	15C-XW-33	2.285	(58)	3	(76)	0.35	(0.16)
2	XW	20D-XW-33	2.520	(64)	5	(127)	0.69	(0.31)
2½	XW	25D-XW-33	3.025	(77)	5	(127)	0.85	(0.38)
3	XW	30D-XW-33	3.520	(89)	5	(127)	1.00	(0.45)
3½	XW	35D-XW-33	4.025	(102)	5	(127)	1.28	(0.58)
4	XW	40D-XW-33	4.520	(115)	7	(178)	1.56	(0.71)
5	XW	50D-XW-33	5.520	(140)	7	(178)	2.08	(0.94)
6	XW	60D-XW-33	6.520	(166)	7	(178)	2.47	(1.12)

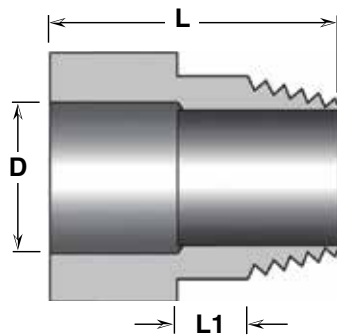

### SPECIAL ADAPTER FOR PVC COATED FITTINGS

[Male Terminal Adapter]

This terminal adapter has tapered threads and a straight shoulder so it can fit under the PVC sleeve of a PVC coated steel fitting.

Nominal Size	Type	Item No.	D		L	L1	Weight			
			lbs	kg	lbs	kg				
¾	XW	07C-XW-24	1.435	(36)	3.75	(95)	0.75	(18)	0.36	(0.16)
1	XW	10C-XW-24	1.700	(43)	4.00	(102)	1.00	(25)	0.50	(0.23)
1¼	XW	12C-XW-24	2.045	(52)	4.25	(108)	1.25	(32)	0.60	(0.27)
1½	XW	15C-XW-24	2.285	(58)	4.50	(114)	1.50	(38)	0.90	(0.41)
2	XW	20D-XW-24	2.520	(64)	7.00	(178)	2.00	(51)	0.69	(0.31)
2½	XW	25D-XW-24	3.025	(77)	7.00	(178)	2.00	(51)	1.20	(0.45)
3	XW	30D-XW-24	3.520	(89)	7.00	(178)	2.00	(51)	1.00	(0.45)
3½	XW	35D-XW-24	4.025	(102)	7.00	(178)	2.00	(51)	1.20	(0.54)
4	XW	40D-XW-24	4.520	(115)	7.00	(178)	2.00	(51)	1.56	(0.71)
5	XW	50D-XW-24	5.520	(140)	7.00	(178)	2.00	(51)	2.08	(0.94)
6	XW	60D-XW-24	6.520	(166)	7.00	(178)	2.00	(51)	2.47	(1.12)

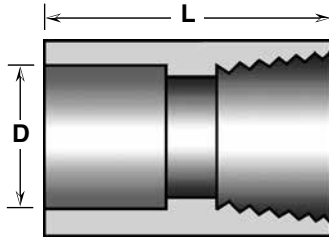

### FEMALE TERMINAL ADAPTER

This adapter is generally used for joining fiberglass conduit with galvanized rigid steel (GRS) conduit. It has the same threads as GRS conduit and can easily be attached to GRS conduit.

Nominal Size	Type	Item No.	D	L	Weight lbs kg
¾	XW	07C-XW-32	1.435 (36)	3 (76)	0.30 (0.14)
1	XW	10C-XW-32	1.700 (43)	3 (76)	0.38 (0.17)
1¼	XW	12C-XW-32	2.045 (52)	3 (76)	0.45 (0.20)
1½	XW	15C-XW-32	2.285 (58)	3 (76)	0.60 (0.27)
2	XW	20D-XW-32	2.520 (64)	5 (127)	1.20 (0.55)
2½	XW	25D-XW-32	3.025 (77)	5 (127)	0.85 (0.38)
3	XW	30D-XW-32	3.520 (89)	5 (127)	1.40 (0.64)
3½	XW	35D-XW-32	4.025 (102)	5 (127)	1.28 (0.58)
4	XW	40D-XW-32	4.520 (115)	7 (178)	2.08 (0.94)
5	XW	50D-XW-32	5.520 (140)	7 (178)	2.60 (1.18)
6	XW	60D-XW-32	6.520 (166)	7 (178)	3.51 (1.59)

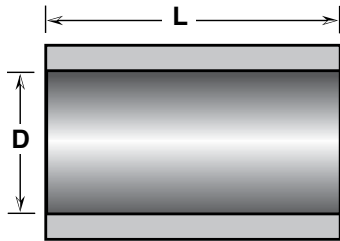

### SLEEVE COUPLING

Nominal Size	Type	Item No.	D	L	Weight lbs kg
¾	XW	07C-XW-42	1.435 (36)	6 (152)	0.22 (0.10)
1	XW	10C-XW-42	1.700 (43)	6 (152)	0.29 (0.13)
1¼	XW	12C-XW-42	2.045 (52)	6 (152)	0.36 (0.16)
1½	XW	15C-XW-42	2.285 (58)	6 (152)	0.39 (0.18)
2	XW	20D-XW-42	2.520 (64)	10 (254)	0.88 (0.40)
2½	XW	25D-XW-42	3.025 (77)	10 (254)	1.08 (0.49)
3	XW	30D-XW-42	3.520 (89)	10 (254)	1.25 (0.57)
3½	XW	35D-XW-42	4.025 (102)	10 (254)	1.87 (0.85)
4	XW	40D-XW-42	4.520 (115)	10 (254)	1.50 (0.68)
5	XW	50D-XW-42	5.520 (140)	10 (254)	2.08 (0.94)
6	XW	60D-XW-42	6.520 (166)	10 (254)	2.50 (1.13)

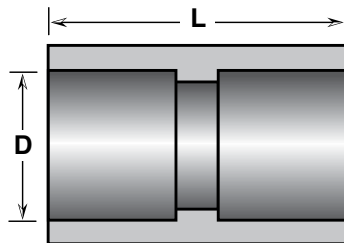

### STOP COUPLING

Nominal Size	Type	Item No.	D	L	Weight lbs kg
¾	XW	07C-XW-40	1.435 (36)	6 (152)	0.22 (0.10)
1	XW	10C-XW-40	1.700 (43)	6 (152)	0.29 (0.13)
1¼	XW	12C-XW-40	2.045 (52)	6 (152)	0.36 (0.16)
1½	XW	15C-XW-40	2.285 (58)	6 (152)	0.39 (0.18)
2	XW	20D-XW-40	2.520 (64)	10 (254)	0.88 (0.40)
2½	XW	25D-XW-40	3.025 (77)	10 (254)	1.08 (0.49)
3	XW	30D-XW-40	3.520 (89)	10 (254)	1.25 (0.57)
3½	XW	35D-XW-40	4.025 (102)	10 (254)	1.87 (0.85)
4	XW	40D-XW-40	4.520 (115)	10 (254)	2.00 (0.91)
5	XW	50D-XW-40	5.520 (140)	10 (254)	2.50 (1.13)
6	XW	60D-XW-40	6.520 (166)	10 (254)	2.90 (1.32)

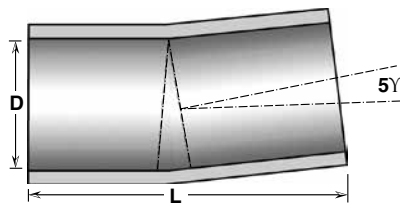

### 5° DOUBLE BELL COUPLING

Other angles can also be manufactured, such as 2.5° etc.

Please contact factory for additional information.

Nominal Size	Type	Item No.	D	L	Weight lbs kg
¾	XW	07C-XW-44	1.435 (36)	6 (152)	0.22 (0.10)
1	XW	10C-XW-44	1.700 (43)	6 (152)	0.29 (0.13)
1¼	XW	12C-XW-44	2.045 (52)	6 (152)	0.36 (0.16)
1½	XW	15C-XW-44	2.285 (58)	6 (152)	0.39 (0.18)
2	XW	20D-XW-44	2.520 (64)	10 (254)	0.92 (0.42)
2½	XW	25D-XW-44	3.025 (77)	10 (254)	1.28 (0.58)
3	XW	30D-XW-44	3.520 (89)	10 (254)	1.48 (0.67)
3½	XW	35D-XW-44	4.025 (102)	10 (254)	1.70 (0.77)
4	XW	40D-XW-44	4.520 (115)	10 (254)	1.53 (0.67)
5	XW	50D-XW-44	5.520 (140)	10 (254)	2.17 (0.98)
6	XW	60D-XW-44	6.520 (166)	10 (254)	2.55 (1.16)

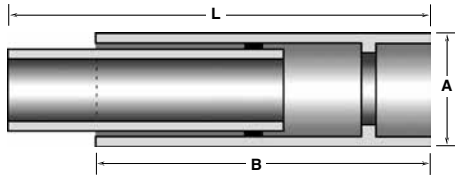

## SINGLE EXPANSION JOINT SOCKET X SPIGOT WITH O-RING

Installation of Expansion Joints:

- When the duct is shorter than 50 ft., no Expansion Joint needed
- When the duct is between 50 ft. up to 200 ft., install one Expansion Joint at the mid point
- If the duct is longer than 200 ft., install one Expansion Joint every 200 ft. apart

*Note: All Expansion Joints have a yellow line on the nipple end of the joint for proper installation.*

Nominal Size	Type	Item No.	A	B	L - Min	L - Max	Weight	
							lbs	kg
¾	XW	07C-XW-36	1.935 (54)	12 (305)	15 (381)	23 (584)	1.40	(0.64)
1	XW	10C-XW-36	2.200 (61)	12 (305)	15 (381)	23 (584)	1.57	(0.71)
1¼	XW	12C-XW-36	2.545 (65)	12 (305)	15 (381)	23 (584)	1.89	(0.86)
1½	XW	15C-XW-36	2.785 (71)	12 (305)	15 (381)	23 (584)	2.72	(1.23)
2	XW	20D-XW-36	3.000 (76)	12 (305)	15 (381)	23 (584)	2.90	(1.32)
2½	XW	25D-XW-36	3.525 (90)	12 (305)	15 (381)	23 (584)	3.56	(1.61)
3	XW	30D-XW-36	4.000 (102)	12 (305)	15 (381)	23 (584)	4.19	(1.90)
3½	XW	35D-XW-36	4.525 (115)	12 (305)	15 (381)	23 (584)	4.83	(2.19)
4	XW	40D-XW-36	5.000 (127)	14 (356)	19 (482)	27 (686)	6.42	(2.92)
5	XW	50D-XW-36	6.000 (152)	14 (356)	19 (482)	27 (686)	7.94	(3.60)
6	XW	60D-XW-36	7.000 (178)	14 (356)	19 (482)	27 (686)	10.06	(4.57)

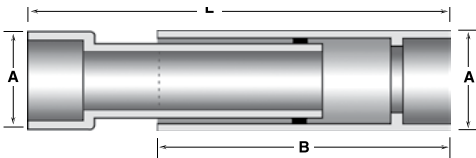

## SINGLE EXPANSION JOINT SOCKET X SOCKET WITH O-RING

Installation of Expansion Joints:

- When the duct is shorter than 50 ft., no Expansion Joint needed
- When the duct is between 50 ft. up to 200 ft., install one Expansion Joint at the mid point
- If the duct is longer than 200 ft., install one Expansion Joint every 200 ft. apart

*Note: All Expansion Joints have a yellow line on the nipple end of the joint for proper installation.*

Nominal Size	Type	Item No.	A	B	L - Min	L - Max	Weight	
							lbs	kg
¾	XW	07C-XW-37	1.935 (54)	12 (305)	15 (381)	23 (584)	1.76	(0.80)
1	XW	10C-XW-37	2.200 (61)	12 (305)	15 (381)	23 (584)	1.97	(0.89)
1¼	XW	12C-XW-37	2.545 (65)	12 (305)	15 (381)	23 (584)	2.35	(1.07)
1½	XW	15C-XW-37	2.785 (71)	12 (305)	15 (381)	23 (584)	2.72	(1.23)
2	XW	20D-XW-37	3.000 (76)	12 (305)	18 (457)	26 (660)	3.62	(1.64)
2½	XW	25D-XW-37	3.525 (90)	12 (305)	18 (457)	26 (660)	4.44	(2.01)
3	XW	30D-XW-37	4.000 (102)	12 (305)	18 (457)	26 (660)	5.23	(2.37)
3½	XW	35D-XW-37	4.525 (115)	12 (305)	18 (457)	26 (660)	6.06	(2.75)
4	XW	40D-XW-37	5.000 (127)	14 (356)	22 (559)	32 (812)	7.89	(3.58)
5	XW	50D-XW-37	6.000 (152)	14 (356)	22 (559)	32 (812)	9.75	(4.43)
6	XW	60D-XW-37	7.000 (178)	14 (356)	22 (559)	32 (812)	12.08	(5.48)

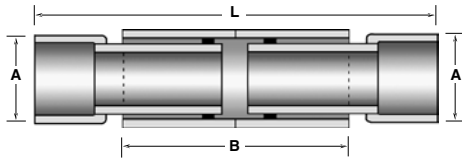

## DOUBLE EXPANSION JOINT WITH O-RING

Double expansion joint is sometimes referred to as back-to-back expansion joint.

Installation of Expansion Joints:

- When the duct is shorter than 50 ft., no Expansion Joint needed
- When the duct is between 50 ft. up to 200 ft., install one Expansion Joint at the mid point
- If the duct is longer than 200 ft., install one Expansion Joint every 200 ft. apart

*Note: All Expansion Joints have a yellow line on the nipple end of the joint for proper installation.*

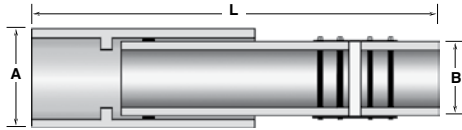

## ALIGNMENT/EXPANSION FITTING, WITH O-RINGS

Alignment/Expansion fitting is sometimes referred to as an Expansion/Deflection joint.

(The clamps holding the rubber sleeve connecting the two nipples are made from stainless steel for ultimate corrosion protection).

Installation of Expansion Joints:

- When the duct is shorter than 50 ft., no Expansion Joint needed
- When the duct is between 50 ft. up to 200 ft., install one Expansion Joint at the mid point
- If the duct is longer than 200 ft., install one Expansion Joint every 200 ft. apart

*Note: All Expansion Joints have a yellow line on the nipple end of the joint for proper installation.*

Nominal Size	Type	Item No.	A	B	L - Min	L - Max	Weight lbs	kg
¾	XW	07C-XW-39	1.935 (54)	17 (432)	29 (737)	45 (1143)	3.01	(1.37)
1	XW	10C-XW-39	2.200 (61)	17 (432)	29 (737)	45 (1143)	3.36	(1.53)
1¼	XW	12C-XW-39	2.545 (65)	17 (432)	29 (737)	45 (1143)	4.06	(1.84)
1½	XW	15C-XW-39	2.785 (71)	17 (432)	29 (737)	45 (1143)	5.83	(2.65)
2	XW	20D-XW-39	3.000 (76)	17 (432)	29 (737)	45 (1143)	6.24	(2.83)
2½	XW	25D-XW-39	3.525 (90)	17 (432)	29 (737)	45 (1143)	7.63	(3.46)
3	XW	30D-XW-39	4.000 (102)	17 (432)	29 (737)	45 (1143)	9.01	(4.09)
3½	XW	35D-XW-39	4.525 (115)	17 (432)	29 (737)	45 (1143)	10.42	(4.72)
4	XW	40D-XW-39	5.000 (127)	17 (432)	29 (737)	45 (1143)	11.78	(5.35)
5	XW	50D-XW-39	6.000 (152)	17 (432)	29 (737)	45 (1143)	14.55	(6.61)
6	XW	60D-XW-39	7.000 (178)	17 (432)	29 (737)	45 (1143)	19.25	(8.74)

Nominal Size	Type	Item No.	A	B	L - Min	L - Max	Weight lbs	kg
¾	XW	07C-XW-31	1.935 (54)	1.410 (36)	37 (940)	51 (1295)	4.27	(1.94)
1	XW	10C-XW-31	2.200 (61)	1.675 (43)	37 (940)	51 (1295)	4.76	(2.16)
1¼	XW	12C-XW-31	2.545 (65)	2.020 (51)	37 (940)	51 (1295)	5.74	(2.60)
1½	XW	15C-XW-31	2.785 (71)	2.260 (57)	37 (940)	51 (1295)	8.26	(3.75)
2	XW	20D-XW-31	3.000 (76)	2.500 (64)	37 (940)	51 (1295)	8.82	(4.00)
2½	XW	25D-XW-31	3.525 (90)	3.000 (76)	37 (940)	51 (1295)	10.78	(4.89)
3	XW	30D-XW-31	4.000 (102)	3.500 (89)	37 (940)	51 (1295)	12.74	(5.78)
3½	XW	35D-XW-31	4.525 (115)	4.000 (102)	37 (940)	51 (1295)	14.70	(6.67)
4	XW	40D-XW-31	5.000 (127)	4.500 (114)	37 (940)	51 (1295)	16.66	(7.56)
5	XW	50D-XW-31	6.000 (152)	5.500 (140)	37 (940)	51 (1295)	20.58	(9.34)
6	XW	60D-XW-31	7.000 (178)	6.500 (165)	37 (940)	51 (1295)	24.50	(11.12)

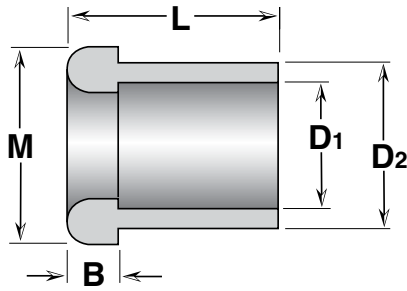

### END BELLS-SOCKET TYPE

End bells are used for creating a permanent termination into a box as well as having a smooth surface that the cable can be pulled over.

Nominal Size	Type	Item No.	D1	D2	L	M	Weight	
							lbs	kg
¾	XW	07C-XW-29	1.432 (36)	1.935 (54)	1.60 (45)	2.48 (63)	0.63	(0.28)
1	XW	10C-XW-29	1.700 (43)	2.200 (61)	1.60 (45)	2.70 (68)	0.70	(0.32)
1¼	XW	12C-XW-29	2.045 (52)	2.545 (65)	1.60 (45)	3.11 (79)	0.85	(0.38)
1½	XW	15C-XW-29	2.285 (58)	2.785 (71)	1.60 (45)	3.35 (85)	1.22	(0.55)
2	XW	20D-XW-29	2.520 (64)	3.020 (76)	3.00 (76)	3.62 (92)	1.30	(0.59)
2½	XW	25D-XW-29	3.025 (77)	3.525 (90)	3.00 (76)	4.22 (107)	1.59	(0.72)
3	XW	30D-XW-29	3.520 (89)	4.020 (102)	3.00 (76)	4.62 (117)	1.90	(0.86)
3½	XW	35D-XW-29	4.025 (102)	4.525 (115)	3.00 (76)	5.48 (139)	2.17	(0.98)
4	XW	40D-XW-29	4.520 (115)	5.020 (128)	5.00 (127)	5.62 (143)	2.40	(1.09)
5	XW	50D-XW-29	5.520 (140)	6.020 (153)	5.00 (127)	6.62 (168)	2.42	(1.10)
6	XW	60D-XW-29	6.520 (166)	7.020 (178)	5.00 (127)	7.62 (194)	2.50	(1.13)

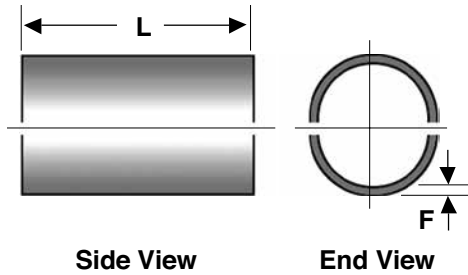

### SPLIT ANCHOR RINGS

Nominal Size	Type	Item No.	F	L	Weight	
					lbs	kg
¾	XW	07C-XW-28	0.25 (6)	3 (76)	0.25	(0.11)
1	XW	10C-XW-28	0.25 (6)	3 (76)	0.28	(0.13)
1¼	XW	12C-XW-28	0.25 (6)	3 (76)	0.34	(0.15)
1½	XW	15C-XW-28	0.25 (6)	3 (76)	0.49	(0.22)
2	XW	20D-XW-28	0.25 (6)	3 (76)	0.52	(0.24)
2½	XW	25D-XW-28	0.25 (6)	3 (76)	0.64	(0.29)
3	XW	30D-XW-28	0.25 (6)	3 (76)	0.80	(0.36)
3½	XW	35D-XW-28	0.25 (6)	3 (76)	0.87	(0.39)
4	XW	40D-XW-28	0.25 (6)	3 (76)	0.98	(0.44)
5	XW	50D-XW-28	0.25 (6)	3 (76)	1.15	(0.52)
6	XW	60D-XW-28	0.25 (6)	3 (76)	1.25	(0.57)

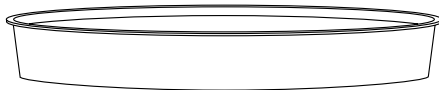

### THERMOPLASTIC PLUG

Nominal Size	Type	Item No.	Weight	
			lbs	kg
¾	XW	07C-XW-26	0.01	(0.005)
1	XW	10C-XW-26	0.01	(0.005)
1¼	XW	12C-XW-26	0.01	(0.005)
1½	XW	15C-XW-26	0.01	(0.005)
2	XW	20D-XW-26	0.01	(0.005)
2½	XW	25D-XW-26	0.01	(0.005)
3	XW	30D-XW-26	0.03	(0.014)
3½	XW	35D-XW-26	0.03	(0.014)
4	XW	40D-XW-26	0.03	(0.014)
5	XW	50D-XW-26	0.06	(0.027)
6	XW	60D-XW-26	0.07	(0.032)

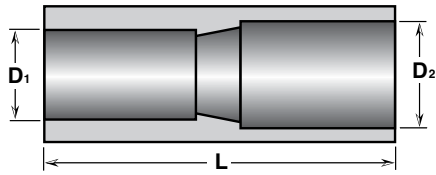

**REDUCING ADAPTER**

Nominal Size	Type	Reducing from and to	Item No.	D <sub>1</sub>	D <sub>2</sub>	L	Weight lbs	kg
1	XW	1 XW - ¾ XW	10C-XW-25-07C-XW	1.43 (36)	1.675 (42)	6 (152)	0.90	(0.41)
1¼	XW	1¼ XW - 1 XW	12C-XW-25-10C-XW	1.70 (43)	2.020 (51)	6 (152)	1.00	(0.45)
1¼	XW	1¼ XW - ¾ XW	12C-XW-25-07C-XW	1.43 (36)	2.020 (51)	6 (152)	1.10	(0.50)
1½	XW	1½ XW - 1½ XW	15C-XW-25-12C-XW	2.04 (52)	2.260 (57)	6 (152)	1.20	(0.54)
1½	XW	1½ XW - 1 XW	15C-XW-25-10C-XW	1.70 (43)	2.260 (57)	6 (152)	1.30	(0.59)
1½	XW	1½ XW - ¾ XW	15C-XW-25-07C-XW	1.43 (36)	2.260 (57)	6 (152)	1.35	(0.61)
2	XW	2 XW - 1½ XW	20D-XW-25-15C-XW	2.28 (58)	2.500 (64)	6 (152)	1.40	(0.64)
2½	XW	2½ XW - 2 XW	25D-XW-25-20D-XW	2.52 (54)	3.000 (76)	6 (152)	1.60	(0.73)
3	XW	3 XW - 2½ XW	30D-XW-25-25D-XW	3.02 (77)	3.500 (89)	6 (152)	1.70	(0.77)
3	XW	3 XW - 2 XW	30D-XW-25-20D-XW	2.52 (64)	3.500 (89)	6 (152)	1.80	(0.82)
3½	XW	3½ XW - 3 XW	35D-XW-25-30D-XW	3.52 (89)	4.000 (102)	6 (152)	2.00	(0.91)
4	XW	4 XW - 3½ XW	40D-XW-25-35D-XW	4.02 (102)	4.500 (114)	6 (152)	2.40	(1.09)
4	XW	4 XW - 3 XW	40D-XW-25-30D-XW	3.52 (89)	4.500 (114)	6 (152)	2.60	(1.18)

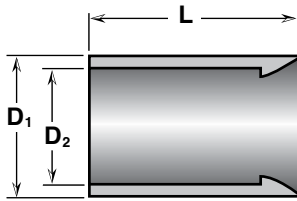

**REDUCING BUSHING**

Nominal Size	Type	Reducing from and to	Item No.	D <sub>1</sub>	D <sub>2</sub>	L	Weight lbs	kg
1	XW	1 XW - ¾ XW	10C-XW-49-07C-XW	1.675 (42)	1.43 (36)	3.000 (76)	0.5	(0.24)
1¼	XW	1¼ XW - 1 XW	12C-XW-49-10C-XW	2.020 (51)	1.70 (43)	3.325 (84)	0.6	(0.25)
1¼	XW	1¼ XW - ¾ XW	12C-XW-49-07C-XW	2.020 (51)	1.43 (36)	3.325 (84)	0.6	(0.25)
1½	XW	1½ XW - 1½ XW	15C-XW-49-12C-XW	2.260 (57)	2.04 (52)	3.325 (84)	0.7	(0.30)
1½	XW	1½ XW - 1 XW	15C-XW-49-10C-XW	2.260 (57)	1.70 (43)	3.325 (84)	0.7	(0.30)
1½	XW	1½ XW - ¾ XW	15C-XW-49-07C-XW	2.260 (57)	1.43 (36)	3.325 (84)	0.8	(0.34)
2	XW	2 XW - 1½ XW	20C-XW-49-15C-XW	2.500 (64)	2.28 (58)	4.000 (102)	0.9	(0.43)
2½	XW	2½ XW - 2 XW	25C-XW-49-20C-XW	3.000 (76)	2.52 (54)	4.000 (102)	1.1	(0.49)
3	XW	3 XW - 2½ XW	30C-XW-49-25C-XW	3.500 (89)	3.02 (77)	4.500 (114)	1.3	(0.58)
3	XW	3 XW - 2 XW	30C-XW-49-20C-XW	3.500 (89)	2.52 (64)	4.500 (114)	1.4	(0.62)
3½	XW	3½ XW - 3 XW	35C-XW-49-30C-XW	4.000 (102)	3.52 (89)	4.500 (114)	1.5	(0.68)
4	XW	4 XW - 3½ XW	40C-XW-49-35C-XW	4.500 (114)	4.02 (102)	4.500 (114)	1.8	(0.82)
4	XW	4 XW - 3 XW	40C-XW-49-30C-XW	4.500 (114)	3.52 (89)	4.500 (114)	2.0	(0.88)

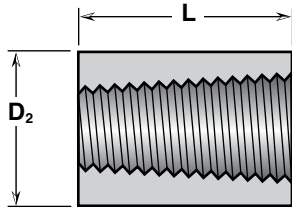

**THREADED REDUCING BUSHING**

Nominal Size	Type	Reducing from and to	Item No.	D <sub>1</sub>	D <sub>2</sub>	L	Weight lbs	kg
¾	XW	¾ XW - ½ Threaded	07C-XW-49-05C-32	--	--	1.41 (36)	2 (52)	0.30 (0.14)

**OFFSET BEND**

When manufacturing offset bends, the vertical offset dimension, H and the horizontal offset dimension, L, need to be specified.

All offset bends are supplied with 6" (152mm) straight ends. (Item numbers for offset bends end with the suffix - 47)

Contact your local sales representative or Champion Fiberglass directly for information.

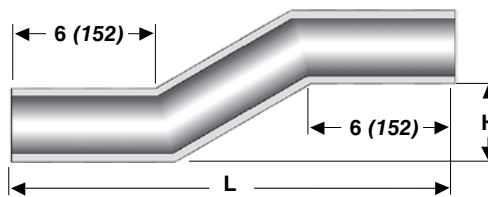

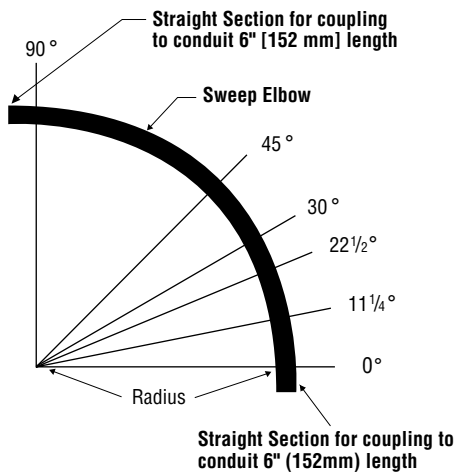

## ELBOWS

Radii listed are available and larger radii can be supplied. Contact your local representative for more information. All bends are supplied with plain ends. To enhance installation, bends can be supplied with one or two bonded on couplings. Contact your local sales representative or Champion Fiberglass directly for information.

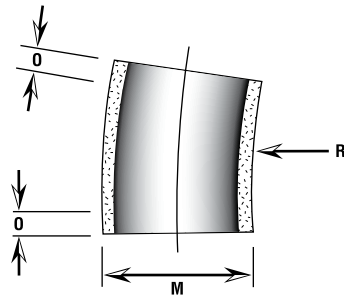

**1 1/4" X 12"**

Nominal Size	Type	Item No.	M	O-Tangent (min)	R - Radius (min)	Weight lbs	kg
¾	XW	07C-XW-50-P	1.41 (36)	6 (152)	12 (305)	0.71	(0.32)
1	XW	10C-XW-50-P	1.68 (43)	6 (152)	12 (305)	0.79	(0.36)
1¼	XW	12C-XW-50-P	2.02 (51)	6 (152)	12 (305)	0.96	(0.43)
1½	XW	15C-XW-50-P	2.26 (57)	6 (152)	12 (305)	1.38	(0.63)
2	XW	20D-XW-50-P	2.50 (63)	6 (152)	12 (305)	1.47	(0.67)
2½	XW	25D-XW-50-P	3.00 (76)	6 (152)	12 (305)	1.80	(0.82)
3	XW	30D-XW-50-P	4.00 (102)	6 (152)	12 (305)	2.45	(1.11)

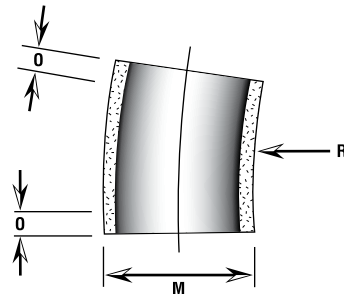

**1 1/4" X 24"**

Nominal Size	Type	Item No.	M	O-Tangent (min)	R - Radius (min)	Weight lbs	kg
¾	XW	07C-XW-51-P	1.41 (36)	6 (152)	24 (610)	0.87	(0.39)
1	XW	10C-XW-51-P	1.68 (43)	6 (152)	24 (610)	0.97	(0.44)
1¼	XW	12C-XW-51-P	2.02 (51)	6 (152)	24 (610)	1.16	(0.53)
1½	XW	15C-XW-51-P	2.26 (57)	6 (152)	24 (610)	1.68	(0.76)
2	XW	20D-XW-51-P	2.50 (63)	6 (152)	24 (610)	1.79	(0.81)
2½	XW	25D-XW-51-P	3.00 (76)	6 (152)	24 (610)	2.19	(0.99)
3	XW	30D-XW-51-P	3.50 (89)	6 (152)	24 (610)	2.58	(1.17)
3½	XW	35D-XW-51-P	4.00 (102)	6 (152)	24 (610)	2.98	(1.35)
4	XW	40D-XW-51-P	4.50 (114)	6 (152)	24 (610)	3.38	(1.53)

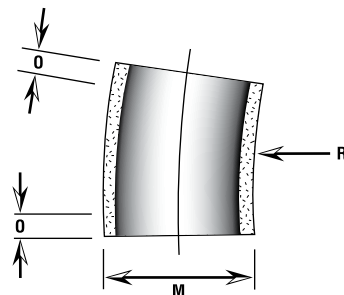

**1 1/4" X 36"**

Nominal Size	Type	Item No.	M	O-Tangent (min)	R - Radius (min)	Weight lbs	kg
¾	XW	07C-XW-52-P	1.41 (36)	6 (152)	36 (914)	0.97	(0.44)
1	XW	10C-XW-52-P	1.68 (43)	6 (152)	36 (914)	1.08	(0.49)
1¼	XW	12C-XW-52-P	2.02 (51)	6 (152)	36 (914)	1.30	(0.59)
1½	XW	15C-XW-52-P	2.26 (57)	6 (152)	36 (914)	1.87	(0.85)
2	XW	20D-XW-52-P	2.50 (64)	6 (152)	36 (914)	2.00	(0.91)
2½	XW	25D-XW-52-P	3.00 (76)	6 (152)	36 (914)	2.44	(1.11)
3	XW	30D-XW-52-P	3.50 (89)	6 (152)	36 (914)	2.88	(1.31)
3½	XW	35D-XW-52-P	4.00 (102)	6 (152)	36 (914)	3.33	(1.51)
4	XW	40D-XW-52-P	4.50 (114)	6 (152)	36 (914)	3.77	(3.77)
5	XW	50D-XW-52-P	5.50 (140)	6 (152)	36 (914)	4.64	(2.11)
6	XW	60D-XW-52-P	6.50 (165)	6 (152)	36 (914)	5.53	(2.51)

# ELBOWS

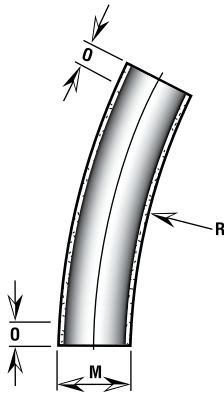

**22½° X 12"**

Nominal Size	Type	Item No.	M	O-Tangent (min)	R - Radius (min)	Weight	
						lbs	kg
¾	XW	07C-XW-60-P	1.41 (36)	6 (152)	12 (305)	0.87	(0.39)
1	XW	10C-XW-60-P	1.68 (43)	6 (152)	12 (305)	0.97	(0.44)
1¼	XW	12C-XW-60-P	2.02 (51)	6 (152)	12 (305)	1.16	(0.53)
1½	XW	15C-XW-60-P	2.26 (57)	6 (152)	12 (305)	1.68	(0.76)
2	XW	20D-XW-60-P	2.50 (63)	6 (152)	12 (305)	1.79	(0.81)
2½	XW	25D-XW-60-P	3.00 (76)	6 (152)	12 (305)	2.19	(0.99)
3	XW	30D-XW-60-P	3.50 (89)	6 (152)	12 (305)	2.58	(1.17)
3½	XW	35D-XW-60-P	4.00 (102)	6 (152)	12 (305)	2.98	(1.35)

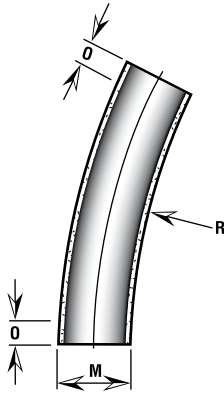

**22½° X 24"**

Nominal Size	Type	Item No.	M	O-Tangent (min)	R - Radius (min)	Weight	
						lbs	kg
¾	XW	07C-XW-61-P	1.41 (36)	6 (152)	24 (610)	1.07	(0.48)
1	XW	10C-XW-61-P	1.68 (43)	6 (152)	24 (610)	1.19	(0.54)
1¼	XW	12C-XW-61-P	2.02 (51)	6 (152)	24 (610)	1.44	(0.65)
1½	XW	15C-XW-61-P	2.26 (57)	6 (152)	24 (610)	2.07	(0.94)
2	XW	20D-XW-61-P	2.50 (65)	6 (152)	24 (610)	2.21	(1.00)
2½	XW	25D-XW-61-P	3.00 (76)	6 (152)	24 (610)	2.70	(1.23)
3	XW	30D-XW-61-P	3.50 (89)	6 (152)	24 (610)	3.32	(1.51)
3½	XW	35D-XW-61-P	4.00 (102)	6 (152)	24 (610)	3.83	(1.74)
4	XW	40D-XW-61-P	4.50 (114)	6 (152)	24 (610)	4.34	(1.97)

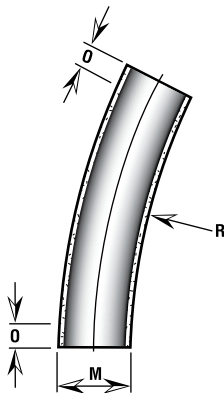

**22½° X 36"**

Nominal Size	Type	Item No.	M	O-Tangent (min)	R - Radius (min)	Weight	
						lbs	kg
¾	XW	07C-XW-62-P	1.41 (36)	6 (152)	36 (914)	1.27	(0.58)
1	XW	10C-XW-62-P	1.68 (43)	6 (152)	36 (914)	1.42	(0.64)
1¼	XW	12C-XW-62-P	2.02 (51)	6 (152)	36 (914)	1.71	(0.77)
1½	XW	15C-XW-62-P	2.26 (57)	6 (152)	36 (914)	2.46	(1.12)
2	XW	20D-XW-62-P	2.50 (65)	6 (152)	36 (914)	2.63	(1.19)
2½	XW	25D-XW-62-P	3.00 (76)	6 (152)	36 (914)	3.21	(1.46)
3	XW	30D-XW-62-P	3.50 (89)	6 (152)	36 (914)	3.79	(1.72)
3½	XW	35D-XW-62-P	4.00 (102)	6 (152)	36 (914)	4.38	(1.99)
4	XW	40D-XW-62-P	4.50 (114)	6 (152)	36 (914)	4.96	(2.25)
5	XW	50D-XW-62-P	5.50 (140)	6 (152)	36 (914)	6.13	(2.78)
6	XW	60D-XW-62-P	6.50 (165)	6 (152)	36 (914)	7.29	(3.31)

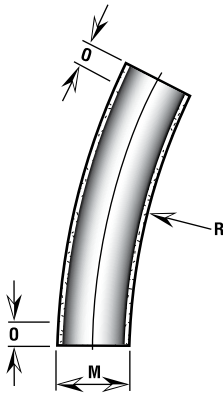

**30° X 12"**

Nominal Size	Type	Item No.	M	O-Tangent (min)	R - Radius (min)	Weight	
						lbs	kg
¾	XW	07C-XW-70-P	1.41 (36)	6 (152)	12 (305)	0.97	(0.44)
1	XW	10C-XW-70-P	1.68 (43)	6 (152)	12 (305)	1.08	(0.49)
1¼	XW	12C-XW-70-P	2.02 (51)	6 (152)	12 (305)	1.30	(0.59)
1½	XW	15C-XW-70-P	2.26 (57)	6 (152)	12 (305)	1.87	(0.85)
2	XW	20D-XW-70-P	2.50 (63)	6 (152)	12 (305)	2.00	(0.91)
2½	XW	25D-XW-70-P	3.00 (76)	6 (152)	12 (305)	2.44	(1.11)
3	XW	30D-XW-70-P	3.50 (89)	6 (152)	12 (305)	2.89	(1.31)
3½	XW	35D-XW-70-P	4.00 (102)	6 (152)	12 (305)	3.33	(1.51)

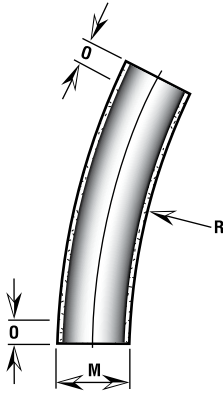

**30° X 24"**

Nominal Size	Type	Item No.	M	O-Tangent (min)	R - Radius (min)	Weight	
						lbs	kg
¾	XW	07C-XW-71-P	1.41 (36)	6 (152)	24 (610)	1.22	(0.55)
1	XW	10C-XW-71-P	1.68 (43)	6 (152)	24 (610)	1.36	(0.62)
1¼	XW	12C-XW-71-P	2.02 (51)	6 (152)	24 (610)	1.64	(0.74)
1½	XW	15C-XW-71-P	2.26 (57)	6 (152)	24 (610)	2.36	(1.07)
2	XW	20D-XW-71-P	2.50 (65)	6 (152)	24 (610)	2.52	(1.14)
2½	XW	25D-XW-71-P	3.00 (76)	6 (152)	24 (610)	3.08	(1.40)
3	XW	30D-XW-71-P	3.50 (89)	6 (152)	24 (610)	3.72	(1.69)
3½	XW	35D-XW-71-P	4.00 (102)	6 (152)	24 (610)	4.30	(1.95)
4	XW	40D-XW-71-P	4.50 (114)	6 (152)	24 (610)	4.87	(2.21)

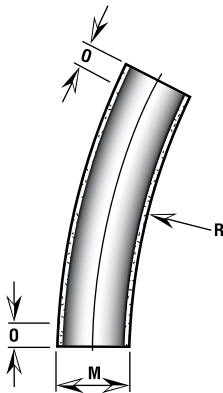

**30° X 36"**

Nominal Size	Type	Item No.	M	O-Tangent (min)	R - Radius (min)	Weight	
						lbs	kg
¾	XW	07C-XW-72-P	1.41 (36)	6 (152)	36 (914)	1.52	(0.69)
1	XW	10C-XW-72-P	1.68 (43)	6 (152)	36 (914)	1.70	(0.77)
1¼	XW	12C-XW-72-P	2.02 (51)	6 (152)	36 (914)	2.05	(0.93)
1½	XW	15C-XW-72-P	2.26 (57)	6 (152)	36 (914)	2.95	(1.34)
2	XW	20D-XW-72-P	2.50 (65)	6 (152)	36 (914)	3.15	(1.43)
2½	XW	25D-XW-72-P	3.00 (76)	6 (152)	36 (914)	3.85	(1.75)
3	XW	30D-XW-72-P	3.50 (89)	6 (152)	36 (914)	4.55	(2.07)
3½	XW	35D-XW-72-P	4.00 (102)	6 (152)	36 (914)	5.25	(2.38)
4	XW	40D-XW-72-P	4.50 (114)	6 (152)	36 (914)	5.95	(2.70)
5	XW	50D-XW-72-P	5.50 (140)	6 (152)	36 (914)	7.35	(3.34)
6	XW	60D-XW-72-P	6.50 (165)	6 (152)	36 (914)	8.75	(3.97)

# ELBOWS

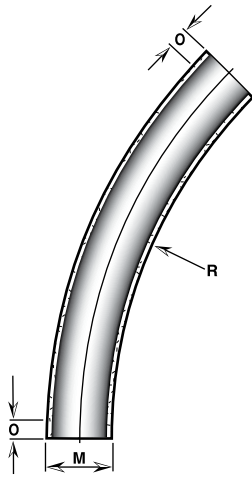

**45° X 12"**

Nominal Size	Type	Item No.	M	O-Tangent (min)	R - Radius (min)	Weight	
						lbs	kg
¾	XW	07C-XW-80-P	1.41 (36)	6 (152)	12 (305)	1.07	(0.48)
1	XW	10C-XW-80-P	1.68 (43)	6 (152)	12 (305)	1.19	(0.54)
1¼	XW	12C-XW-80-P	2.02 (51)	6 (152)	12 (305)	1.44	(0.65)
1½	XW	15C-XW-80-P	2.26 (57)	6 (152)	12 (305)	2.07	(0.94)
2	XW	20D-XW-80-P	2.50 (63)	6 (152)	12 (305)	2.21	(1.00)
2½	XW	25D-XW-80-P	3.00 (76)	6 (152)	12 (305)	2.70	(1.22)
3	XW	30D-XW-80-P	3.50 (89)	6 (152)	12 (305)	2.89	(1.31)
3½	XW	35D-XW-80-P	4.00 (102)	6 (152)	12 (305)	3.68	(1.67)

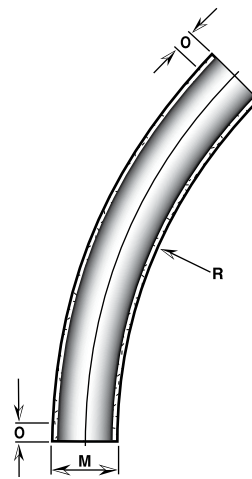

**45° X 24"**

Nominal Size	Type	Item No.	M	O-Tangent (min)	R - Radius (min)	Weight	
						lbs	kg
¾	XW	07C-XW-81-P	1.41 (36)	6 (152)	24 (610)	1.52	(0.69)
1	XW	10C-XW-81-P	1.68 (43)	6 (152)	24 (610)	1.70	(0.77)
1¼	XW	12C-XW-81-P	2.02 (51)	6 (152)	24 (610)	2.05	(0.93)
1½	XW	15C-XW-81-P	2.26 (57)	6 (152)	24 (610)	2.95	(1.34)
2	XW	20D-XW-81-P	2.50 (65)	6 (152)	24 (610)	3.15	(1.43)
2½	XW	25D-XW-81-P	3.00 (76)	6 (152)	24 (610)	3.85	(1.75)
3	XW	30D-XW-81-P	3.50 (89)	6 (152)	24 (610)	4.55	(2.07)
3½	XW	35D-XW-81-P	4.00 (102)	6 (152)	24 (610)	5.24	(2.38)
4	XW	40D-XW-81-P	4.50 (114)	6 (152)	24 (610)	5.95	(2.70)

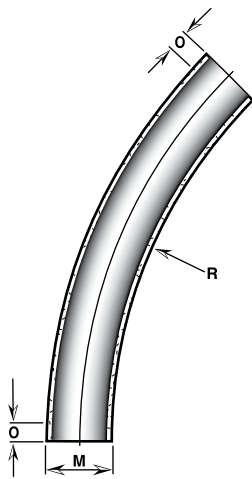

**45° X 36"**

Nominal Size	Type	Item No.	M	O-Tangent (min)	R - Radius (min)	Weight	
						lbs	kg
¾	XW	07C-XW-82-P	1.41 (36)	6 (152)	36 (914)	2.03	(0.92)
1	XW	10C-XW-82-P	1.68 (43)	6 (152)	36 (914)	2.27	(1.03)
1¼	XW	12C-XW-82-P	2.02 (51)	6 (152)	36 (914)	2.73	(1.24)
1½	XW	15C-XW-82-P	2.26 (57)	6 (152)	36 (914)	3.93	(1.78)
2	XW	20D-XW-82-P	2.50 (65)	6 (152)	36 (914)	4.20	(1.91)
2½	XW	25D-XW-82-P	3.00 (76)	6 (152)	36 (914)	5.13	(2.33)
3	XW	30D-XW-82-P	3.50 (89)	6 (152)	36 (914)	6.07	(2.76)
3½	XW	35D-XW-82-P	4.00 (102)	6 (152)	36 (914)	6.99	(3.18)
4	XW	40D-XW-82-P	4.59 (114)	6 (152)	36 (914)	7.93	(3.60)
5	XW	50D-XW-82-P	5.50 (140)	6 (152)	36 (914)	9.79	(4.44)
6	XW	60D-XW-82-P	6.50 (165)	6 (152)	36 (914)	11.65	(5.29)

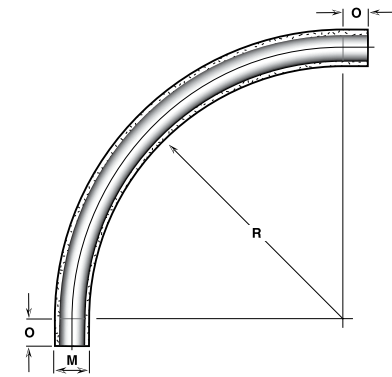

**90° X 12"**

Nominal Size	Type	Item No.	M	O-Tangent (min)	R - Radius (min)	Weight lbs	kg
¾	XW	07C-XW-90-P	1.41 (36)	6 (152)	12 (305)	1.52 (0.69)	
1	XW	10C-XW-90-P	1.68 (43)	6 (152)	12 (305)	1.70 (0.77)	
1¼	XW	12C-XW-90-P	2.02 (51)	6 (152)	12 (305)	2.05 (0.93)	
1½	XW	15C-XW-90-P	2.26 (57)	6 (152)	12 (305)	2.95 (1.34)	
2	XW	20D-XW-90-P	2.50 (63)	6 (152)	12 (305)	3.15 (1.43)	
2½	XW	25D-XW-90-P	3.00 (76)	6 (152)	12 (305)	3.85 (1.75)	
3	XW	30D-XW-90-P	3.50 (89)	6 (152)	12 (305)	4.55 (2.06)	
3½	XW	35D-XW-90-P	4.00 (102)	6 (152)	12 (305)	5.25 (2.38)	

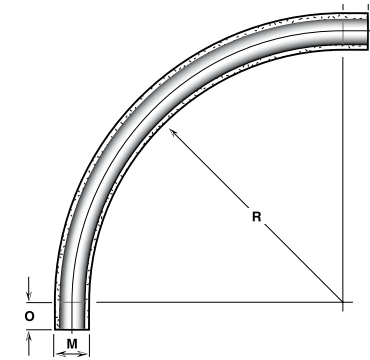

**90° X 24"**

Nominal Size	Type	Item No.	M	O-Tangent (min)	R - Radius (min)	Weight lbs	kg
¾	XW	07C-XW-91-P	1.41 (36)	6 (152)	24 (610)	2.54 (1.15)	
1	XW	10C-XW-91-P	1.68 (43)	6 (152)	24 (610)	2.83 (1.29)	
1¼	XW	12C-XW-91-P	2.02 (51)	6 (152)	24 (610)	3.42 (1.55)	
1½	XW	15C-XW-91-P	2.26 (57)	6 (152)	24 (610)	4.92 (2.23)	
2	XW	20D-XW-91-P	2.50 (65)	6 (152)	24 (610)	5.25 (2.38)	
2½	XW	25D-XW-91-P	3.00 (76)	6 (152)	24 (610)	6.42 (2.92)	
3	XW	30D-XW-91-P	3.50 (89)	6 (152)	24 (610)	7.58 (3.44)	
3½	XW	35D-XW-91-P	4.00 (102)	6 (152)	24 (610)	8.76 (3.98)	
4	XW	40D-XW-91-P	4.50 (114)	6 (152)	24 (610)	9.92 (4.50)	

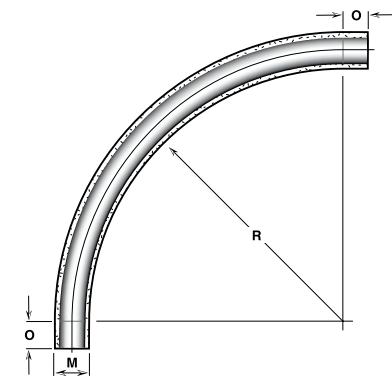

**90° X 36"**

Nominal Size	Type	Item No.	M	O-Tangent (min)	R - Radius (min)	Weight lbs	kg
¾	XW	07C-XW-92-P	1.41 (36)	6 (152)	36 (914)	3.46 (1.57)	
1	XW	10C-XW-92-P	1.68 (43)	6 (152)	36 (914)	3.85 (1.75)	
1¼	XW	12C-XW-92-P	2.02 (51)	6 (152)	36 (914)	4.65 (2.11)	
1½	XW	15C-XW-92-P	2.26 (57)	6 (152)	36 (914)	6.69 (3.04)	
2	XW	20D-XW-92-P	2.50 (65)	6 (152)	36 (914)	7.14 (3.24)	
2½	XW	25D-XW-92-P	3.00 (76)	6 (152)	36 (914)	8.73 (3.96)	
3	XW	30D-XW-92-P	3.50 (89)	6 (152)	36 (914)	10.31 (4.68)	
3½	XW	35D-XW-92-P	4.00 (102)	6 (152)	36 (914)	11.90 (5.40)	
4	XW	40D-XW-92-P	4.50 (114)	6 (152)	36 (914)	13.49 (6.12)	
5	XW	50D-XW-92-P	5.50 (140)	6 (152)	36 (914)	16.79 (7.56)	
6	XW	60D-XW-92-P	6.50 (165)	6 (152)	36 (914)	19.99 (9.00)	

Note: For different radii, degree and/or length for any elbow not shown in this catalog, please contact your local sales representative or the Champion Fiberglass office.

## XW STANDARD RADIUS 90° ELBOWS

Standard radius elbows are available in 11¼, 22½, 30 and 45 degree bends as well. Please contact factory for additional information regarding pricing, dimensions, weights and part numbers.

Nominal Size	Type	Item No.	M	O-Tangent (min)	R - Radius (min)	Weight lbs	kg
¾	XW	07C-XW-9SR-P	1.05 (27)	6 (152)	4.50 (114)	.98 (0.4)	
1	XW	10C-XW-9SR-P	1.32 (33)	6 (152)	5.75 (146)	1.19 (0.5)	
1¼	XW	12C-XW-9SR-P	1.66 (42)	6 (152)	7.25 (184)	1.62 (0.7)	
1½	XW	15C-XW-9SR-P	1.90 (48)	6 (152)	8.25 (210)	2.42 (1.1)	
2	XW	20D-XW-9SR-P	2.37 (60)	6 (152)	9.50 (241)	2.87 (1.3)	

## CONDUIT BODIES

All conduit bodies are manufactured by compression molding for ultimate strength. The conduit bodies are made of resin with high glass content, flame retardant per UL 2515 and CSA C22.2 No. 2515 and halogen free. Each conduit body is supplied with a high performance rubber gasket to provide a water tight seal between the cover and conduit body. All hardware is stainless steel for ultimate corrosion protection.

### TYPE C

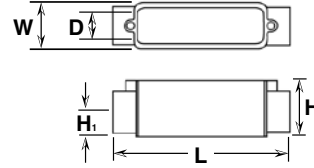

Nominal Size	Type	IPS Item No. Aboveground	L		H		W		H <sub>1</sub>		D	Volume	Weight			
			inch	(mm)	inch	(mm)	inch	(mm)	inch	(mm)				inch	(mm)	cu in
¾	XW	07C-XW-C	8.375	(213)	2.375	(60)	1.840	(47)	1.000	(25)	1.435	(36)	13.90	(228)	0.70	(0.32)
1	XW	10C-XW-C	8.375	(213)	2.375	(60)	1.840	(47)	1.000	(25)	1.700	(43)	13.90	(228)	0.70	(0.32)
1¼	XW	12C-XW-C	10.125	(257)	2.875	(73)	2.540	(64)	1.188	(30)	2.045	(52)	32.00	(524)	1.20	(0.54)
1½	XW	15C-XW-C	10.125	(257)	2.875	(73)	2.540	(64)	1.188	(30)	2.285	(58)	32.00	(524)	1.10	(0.50)
2	XW	20D-XW-C	13.375	(340)	4.000	(102)	3.040	(77)	1.812	(46)	2.520	(64)	70.75	(1160)	2.50	(1.13)
2½	XW	25D-XW-C	13.375	(340)	4.000	(102)	3.040	(77)	1.812	(46)	3.025	(77)	70.75	(1160)	2.50	(1.13)
3	XW	30D-XW-C	21.750	(552)	6.000	(152)	5.875	(149)	3.000	(76)	3.520	(89)	425.00	(6964)	4.24	(1.92)
3½	XW	35D-XW-C	21.750	(552)	6.000	(152)	5.875	(149)	3.000	(76)	4.025	(102)	425.00	(6964)	4.24	(1.92)
4	XW	40D-XW-C	21.750	(552)	6.000	(152)	5.875	(149)	3.000	(76)	4.520	(115)	425.00	(6964)	4.24	(1.92)

### TYPE LB

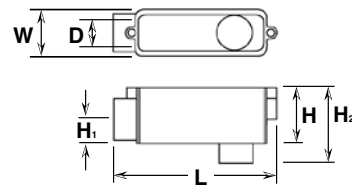

Nominal Size	Type	IPS Item No. Aboveground	L		H		W		H <sub>1</sub>		H <sub>2</sub>		D	Volume	Weight			
			inch	(mm)	inch	(mm)	inch	(mm)	inch	(mm)	inch	(mm)				inch	(mm)	cu in
¾	XW	07C-XW-LB	7.375	(187)	2.375	(60)	1.840	(47)	1.000	(25)	3.900	(99)	1.435	(36)	13.90	(228)	0.70	(0.32)
1	XW	10C-XW-LB	7.375	(187)	2.375	(60)	1.840	(47)	1.000	(25)	3.900	(99)	1.700	(43)	13.90	(228)	0.70	(0.32)
1¼	XW	12C-XW-LB	9.000	(229)	2.875	(73)	2.540	(64)	1.188	(30)	4.875	(124)	2.045	(52)	32.00	(524)	1.20	(0.54)
1½	XW	15C-XW-LB	9.000	(229)	2.875	(73)	2.540	(64)	1.188	(30)	4.875	(124)	2.285	(58)	32.00	(524)	1.10	(0.50)
2	XW	20D-XW-LB	11.250	(286)	4.000	(102)	3.040	(77)	1.812	(46)	6.687	(170)	2.520	(64)	70.75	(1160)	2.50	(1.13)
2½	XW	25D-XW-LB	11.250	(286)	4.000	(102)	3.040	(77)	1.812	(46)	6.687	(170)	3.025	(77)	70.75	(1160)	2.50	(1.13)
3	XW	30D-XW-LB	16.125	(410)	6.000	(152)	5.875	(149)	3.000	(76)	8.750	(222)	3.520	(89)	425.00	(6964)	4.25	(1.92)
3½	XW	35D-XW-LB	16.125	(410)	6.000	(152)	5.875	(149)	3.000	(76)	8.750	(222)	4.025	(102)	425.00	(6964)	4.25	(1.92)
4	XW	40D-XW-LB	16.125	(410)	6.000	(152)	5.875	(149)	3.000	(76)	8.750	(222)	4.520	(115)	425.00	(6964)	4.25	(1.92)

### TYPE LL

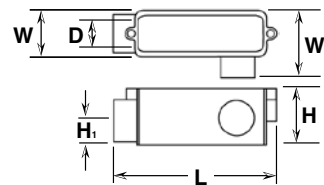

Nominal Size	Type	IPS Item No. Aboveground	L		H		W		W <sub>1</sub>		H <sub>1</sub>		D	Volume	Weight			
			inch	(mm)	inch	(mm)	inch	(mm)	inch	(mm)	inch	(mm)				inch	(mm)	cu in
¾	XW	07C-XW-LL	7.375	(187)	2.375	(60)	1.840	(47)	3.500	(89)	1.000	(25)	1.435	(36)	13.90	(228)	0.70	(0.32)
1	XW	10C-XW-LL	7.375	(187)	2.375	(60)	1.840	(47)	3.500	(89)	1.000	(25)	1.700	(43)	13.90	(228)	0.70	(0.32)
1¼	XW	12C-XW-LL	9.000	(229)	2.875	(73)	2.540	(64)	4.500	(114)	1.188	(30)	2.045	(52)	32.00	(524)	1.20	(0.54)
1½	XW	15C-XW-LL	9.000	(229)	2.875	(73)	2.540	(64)	4.500	(114)	1.188	(30)	2.285	(58)	32.00	(524)	1.10	(0.50)
2	XW	20D-XW-LL	11.250	(286)	4.000	(102)	3.040	(77)	5.500	(140)	1.812	(46)	2.520	(64)	70.75	(1160)	2.50	(1.13)
2½	XW	25D-XW-LL	11.250	(286)	4.000	(102)	3.040	(77)	5.500	(140)	1.812	(46)	3.025	(77)	70.75	(1160)	2.50	(1.13)
3	XW	30D-XW-LL	16.125	(410)	6.000	(152)	5.875	(149)	8.750	(222)	3.000	(76)	3.520	(89)	425.00	(6964)	4.24	(1.92)
3½	XW	35D-XW-LL	16.125	(410)	6.000	(152)	5.875	(149)	8.750	(222)	3.000	(76)	4.025	(102)	425.00	(6964)	4.24	(1.92)
4	XW	40D-XW-LL	16.125	(410)	6.000	(152)	5.875	(149)	8.750	(222)	3.000	(76)	4.520	(115)	425.00	(6964)	4.24	(1.92)

### TYPE LR

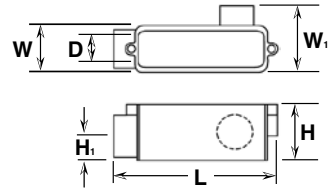

Nominal Size	Type	IPS Item No. Aboveground	L		H		W		W <sub>1</sub>	H <sub>1</sub>	D	Volume		Weight			
			inch	(mm)	inch	(mm)	inch	(mm)				inch	(mm)	cu in	(cm <sup>3</sup> )	lbs	(kg)
¾	XW	07C-XW-LR	7.375	(187)	2.375	(60)	1.840	(47)	3.500	(89)	1.000	1.435	(36)	13.90	(228)	0.70	(0.32)
1	XW	10C-XW-LR	7.375	(187)	2.375	(60)	1.840	(47)	3.500	(89)	1.000	1.700	(43)	13.90	(228)	0.70	(0.32)
1¼	XW	12C-XW-LR	9.000	(229)	2.875	(73)	2.540	(64)	4.500	(114)	1.188	2.045	(52)	32.00	(524)	1.20	(0.54)
1½	XW	15C-XW-LR	9.000	(229)	2.875	(73)	2.540	(64)	4.500	(114)	1.188	2.285	(58)	32.00	(524)	1.10	(0.50)
2	XW	20D-XW-LR	11.250	(286)	4.000	(102)	3.040	(77)	5.500	(140)	1.812	2.520	(64)	70.75	(1160)	2.50	(1.13)
2½	XW	25D-XW-LR	11.250	(286)	4.000	(102)	3.040	(77)	5.500	(140)	1.812	3.025	(77)	70.75	(1160)	2.50	(1.13)
3	XW	30D-XW-LR	16.125	(410)	6.000	(152)	5.875	(149)	8.750	(222)	3.000	3.520	(89)	425.00	(6964)	4.24	(1.92)
3½	XW	35D-XW-LR	16.125	(410)	6.000	(152)	5.875	(149)	8.750	(222)	3.000	4.025	(102)	425.00	(6964)	4.24	(1.92)
4	XW	40D-XW-LR	16.125	(410)	6.000	(152)	5.875	(149)	8.750	(222)	3.000	4.520	(115)	425.00	(6964)	4.24	(1.92)

### TYPE T

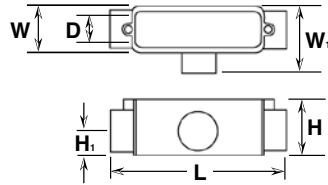

Nominal Size	Type	IPS Item No. Aboveground	L		H		W		W <sub>1</sub>	H <sub>1</sub>	D	Volume		Weight			
			inch	(mm)	inch	(mm)	inch	(mm)				inch	(mm)	cu in	(cm <sup>3</sup> )	lbs	(kg)
¾	XW	07C-XW-T	8.375	(213)	2.375	(60)	1.840	(47)	3.500	(89)	1.000	1.435	(36)	13.90	(228)	0.70	(0.32)
1	XW	10C-XW-T	8.375	(213)	2.375	(60)	1.840	(47)	3.500	(89)	1.000	1.700	(43)	13.90	(228)	0.70	(0.32)
1¼	XW	12C-XW-T	10.125	(257)	3.000	(76)	2.540	(64)	4.437	(113)	1.188	2.045	(52)	32.00	(524)	1.40	(0.64)
1½	XW	15C-XW-T	10.125	(257)	3.000	(76)	2.540	(64)	4.437	(113)	1.188	2.285	(58)	32.00	(524)	1.30	(0.59)
2	XW	20D-XW-T	13.375	(340)	4.000	(102)	3.040	(77)	5.500	(140)	1.812	2.520	(64)	70.75	(1160)	2.80	(1.27)
2½	XW	25D-XW-T	13.375	(340)	4.000	(102)	3.040	(77)	5.500	(140)	1.812	3.025	(77)	70.75	(1160)	2.50	(1.13)
3	XW	30D-XW-T	21.750	(552)	6.000	(152)	5.875	(149)	8.750	(222)	3.000	3.520	(89)	425.00	(6964)	4.24	(1.92)
3½	XW	35D-XW-T	21.750	(552)	6.000	(152)	5.875	(149)	8.750	(222)	3.000	4.025	(102)	425.00	(6964)	4.24	(1.92)
4	XW	40D-XW-T	21.750	(552)	6.000	(152)	5.875	(149)	8.750	(222)	3.000	4.520	(115)	425.00	(6964)	4.24	(1.92)

### TYPE TB

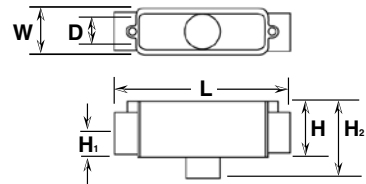

Nominal Size	Type	IPS Item No. Aboveground	L		H		W		H <sub>1</sub>	H <sub>2</sub>	D	Volume		Weight			
			inch	(mm)	inch	(mm)	inch	(mm)				inch	(mm)	cu in	(cm <sup>3</sup> )	lbs	(kg)
¾	XW	07C-XW-TB	8.375	(213)	2.375	(60)	1.840	(47)	1.000	(25)	3.900	1.435	(36)	13.90	(228)	0.70	(0.32)
1	XW	10C-XW-TB	8.375	(213)	2.375	(60)	1.840	(47)	1.000	(25)	3.900	1.700	(43)	13.90	(228)	0.70	(0.32)
1¼	XW	12C-XW-TB	10.125	(257)	3.000	(76)	2.540	(64)	1.188	(30)	4.875	2.045	(52)	32.00	(524)	1.40	(0.64)
1½	XW	15C-XW-TB	10.125	(257)	3.000	(76)	2.540	(64)	1.188	(30)	4.875	2.285	(58)	32.00	(524)	1.30	(0.59)
2	XW	20D-XW-TB	13.375	(340)	4.000	(102)	3.040	(77)	1.812	(46)	6.687	2.520	(64)	70.75	(1160)	2.80	(1.27)
2½	XW	25D-XW-TB	13.375	(340)	4.000	(102)	3.040	(77)	1.812	(46)	6.687	3.025	(77)	70.75	(1160)	2.50	(1.13)
3	XW	30D-XW-TB	21.750	(552)	6.000	(152)	5.875	(149)	3.000	(76)	8.750	3.520	(89)	425.00	(6964)	4.24	(1.92)
3½	XW	35D-XW-TB	21.750	(552)	6.000	(152)	5.875	(149)	3.000	(76)	8.750	4.025	(102)	425.00	(6964)	4.24	(1.92)
4	XW	40D-XW-TB	21.750	(552)	6.000	(152)	5.875	(149)	3.000	(76)	8.750	4.520	(115)	425.00	(6964)	4.24	(1.92)

### TYPE X

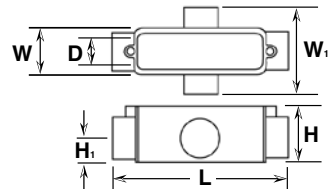

Nominal Size	Type	IPS Item No. Aboveground	L		H		W		W <sub>1</sub>	H <sub>1</sub>	D	Volume		Weight			
			inch	(mm)	inch	(mm)	inch	(mm)				inch	(mm)	cu in	(cm <sup>3</sup> )	lbs	(kg)
¾	XW	07C-XW-X	8.375	(213)	2.375	(60)	1.840	(47)	4.750	(121)	1.000	1.435	(36)	13.90	(228)	0.70	(0.32)
1	XW	10C-XW-X	8.375	(213)	2.375	(60)	1.840	(47)	4.750	(121)	1.000	1.700	(43)	13.90	(228)	0.70	(0.32)
1¼	XW	12C-XW-X	10.125	(257)	3.000	(76)	2.540	(64)	6.437	(163)	1.188	2.045	(52)	32.00	(524)	1.60	(0.73)
1½	XW	15C-XW-X	10.125	(257)	3.000	(76)	2.540	(64)	6.437	(163)	1.188	2.285	(58)	32.00	(524)	1.50	(0.68)
2	XW	20D-XW-X	13.375	(340)	4.000	(102)	3.040	(77)	7.188	(182)	1.812	2.520	(64)	70.75	(1160)	3.00	(1.36)
2½	XW	25D-XW-X	13.375	(340)	4.000	(102)	3.040	(77)	7.188	(182)	1.812	3.025	(77)	70.75	(1160)	2.50	(1.13)
3	XW	30D-XW-X	21.750	(552)	6.000	(152)	5.875	(149)	11.500	(292)	3.000	3.520	(89)	425.00	(6964)	4.24	(1.92)
3½	XW	35D-XW-X	21.750	(552)	6.000	(152)	5.875	(149)	11.500	(292)	3.000	4.025	(102)	425.00	(6964)	4.24	(1.92)
4	XW	40D-XW-X	21.750	(552)	6.000	(152)	5.875	(149)	11.500	(292)	3.000	4.520	(115)	425.00	(6964)	4.24	(1.92)

## CHAMPION MIX® (EPOXY ADHESIVE)

The CHAMPION MIX® system is a two part adhesive, epoxy resin system, designed to permanently bond fittings and joints of fiberglass reinforced epoxy pipe. It is also designed for use with pultruded polyester and vinyl ester components. Each cartridge system contains resin, hardener, and one plastic static mixer. An adhesive gun is required for applying the adhesive (ordered separately).

Under normal conditions, it takes approximately 45 minutes for the CM-2040 and CM-2070 adhesives to harden at their rated temperatures. If a faster setting adhesive is desired, there are Champion Mix adhesives available that gel much faster.

The "Fast Gel" adhesives can be specified by adding the suffixes, "FG" or "SFG" to the part numbers. Because the "Fast Gel" and "Super-Fast Gel" adhesives set up quicker, additional mixing tubes may be required.

*Note: Proper mixing can be visually ascertained when the epoxy mixture is evenly gray.*

Part Number	Temperature Range	Approximate Curing Time
CM-2040	40° - 70° F (4° C - 21° C)	30 – 45 minutes
CM-2040 - FG	40° - 70° F (4° C - 21° C)	20 – 30 minutes
CM-2040 - SFG	40° - 70° F (4° C - 21° C)	3 – 7 minutes
CM-2070	70° F (21° C) and above	30 – 45 minutes
CM-2070 - FG	70° F (21° C) and above	20 – 30 minutes
CM-2070 - SFG	70° F (21° C) and above	3 – 7 minutes

CM-MT	Mixing Tip
CM-AG	Adhesive Gun

Estimated Number of Joints Per Container							
<i>(estimated only, as it varies depending on the amount of adhesive applied per application)</i>							
¾"	100 Joints	1½"	60 Joints	3"	35 Joints	5"	20 Joints
1"	85 Joints	2"	50 Joints	3½"	30 Joints	6"	15 Joints
1¼"	75 Joints	2½"	40 Joints	4"	25 Joints		



Adhesive gun



Epoxy Cartridge & Mixer Tip



Assembled Unit

## EPOXY ADHESIVE KIT

Champion Fiberglass Adhesive Kit, contains two cans, one with base adhesive (black color) and the other with hardener (white color), stir sticks, sand paper for abrading conduit surfaces and instruction sheet. When properly mixed, the adhesive will be evenly gray.

The adhesive kit is offered for three different ambient curing temperatures:

- Item# CF-1070, for 70°F (**21°C**) ambient temperature (standard grade)
- Item# CF-1040, for 40°F (**4°C**) ambient temperature (special grade)
- Item# CF-1020, for 20°F (**-7°C**) ambient temperature (special grade)



Adhesive curing time is dependent on the ambient temperature. As a guideline, the CF-1070 adhesive is cured at 75°F (**29°C**) in 1 hour. Contact Champion Fiberglass for curing information at extreme temperatures (high or low). Champion Fiberglass adhesive can be used for bonding fiberglass and PVC together.

Estimated Number of Joints Per Kit <i>(estimated only, as it varies depending on the amount of adhesive applied per application)</i>					
¾"	40 Joints	1½"	25 Joints	3"	15 Joints
1"	35 Joints	2"	20 Joints	3½"	13 Joints
1¼"	30 Joints	2½"	18 Joints	4"	10 Joints

Champion Fiberglass, Inc. offers a complete support system for installations of above ground conduit. The Haz Duct, pipe clamps etc. are manufactured in house and made from high quality fiberglass. **Please note that for standard support systems, only IPS type of fiberglass conduit can be used (If ID/Tubular type of conduit is used, Please consult factory prior to installation).**

### SINGLE STRUT

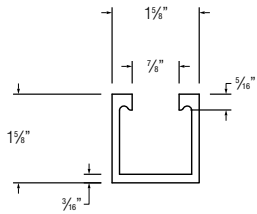

CS-S-15-10-P/V\*

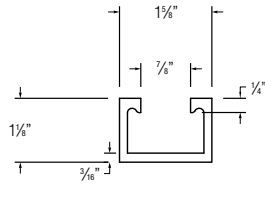

CS-S-11-10-P/V\*

### DOUBLE "BACK TO BACK" STRUT

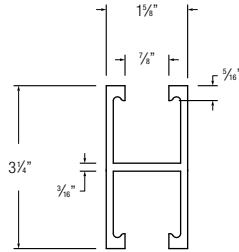

CS-S-15D-10-P/V\*

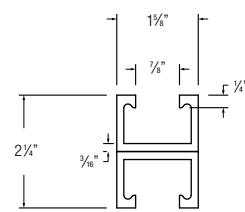

CS-S-11D-10-P/V\*

\* Use P for polyester resin and V for vinyl ester resin.

\* Use P for polyester resin and V for vinyl ester resin.

### "NON-METALLIC" UNIVERSAL PIPE CLAMPS

Champion Fiberglass rigid pipe clamps are IPS sized therefore can be used with all IPS sized conduit (PVC, galvanized rigid metal conduit and Champion Duct). They are constructed from a special grade of glass reinforced vinyl ester resin and supplied with non-metallic bolts and hex nuts. Follow the chart recommendations below to choose the proper sized fiberglass rigid pipe clamp for your Champion XW Haz Duct application.

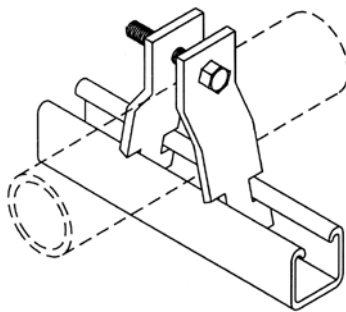

XW Conduit Size	O.D. of XW Conduit	Champion Fiberglass Rigid Pipe Clamp Part No.
¾ XW	1.410 (36)	CS-PC-1-V
1 XW	1.675 (42)	CS-PC-1.25-V
1¼ XW	2.020 (51)	CS-PC-1.5-V
1½ XW	2.260 (57)	CS-PC-2-V
2 XW	2.500 (64)	CS-PC-2-V
2½ XW	3.000 (76)	CS-PC-2.5-V
3 XW	3.500 (89)	CS-PC-3-V
3½ XW	4.000 (102)	CS-PC-3.5-V
4 XW	4.500 (114)	CS-PC-4-V

### FIBERGLASS CLEVIS HANGERS

Design loads have a 3:1 safety factor at 120°F. Insulation may be required at higher temperatures.

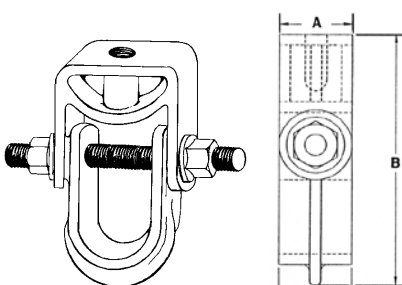

Part No.	Nominal Diameter in	Max Pipe OD in (mm)	Hanger Rod in (mm)	Maximum Load in (mm)	A in (mm)	B in (mm)	C in (mm)
CS-CH-3/4	¾	1 (25)	½ (13)	200 (90)	2.53 (64)	4.52 (115)	1.25 (32)
CS-CH-1	1	1½ (38)	½ (13)	200 (90)	2.53 (64)	4.52 (115)	1.25 (32)
CS-CH-1.25	1¼	1¾ (44)	½ (13)	200 (90)	3.06 (78)	5.14 (131)	1.25 (32)
CS-CH-1.5	1½	2 (51)	½ (13)	200 (90)	3.06 (78)	5.14 (131)	1.25 (32)
CS-CH-2	2	2¾ (67)	½ (13)	300 (135)	3.68 (93)	6.52 (166)	1.25 (32)
CS-CH-2.5	2½	3¼ (83)	¾ (16)	400 (180)	3.68 (93)	6.52 (166)	1.25 (32)
CS-CH-3	3	3¾ (98)	¾ (16)	600 (270)	7.04 (179)	10.00 (254)	1.50 (38)
CS-CH-4	4	5 (130)	¾ (16)	600 (270)	7.04 (179)	10.00 (254)	1.50 (38)
CS-CH-6	6	7 (181)	¾ (16)	600 (270)	9.36 (238)	12.33 (313)	2.04 (52)



**CHAMPION THREAD®** Fasteners and Hanging Systems are specially developed to give optimum strength and chemical corrosion resistance. The systems are excellent for all structural, mechanical and electrical applications where components must be corrosion resistant. All nuts are hex type and standard tools can be used for easy assembly.

## NON-METALLIC U-BOLT

U-Bolts are made from a fiberglass reinforced urethane material and are recommended for temperatures ranging from -40°F to +150°F. 2 FRP nuts included with each U-Bolt.

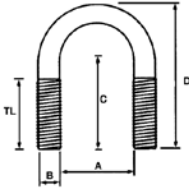

Part No.	Pipe Nom Dia	Dimensions					Load Ratings	
		A in (mm)	B in (mm)	C in (mm)	D in (mm)	TL in (mm)	Max Rec Load lbs (kg)	Max Rec Torque ft lbs (kgm)
OS-UB-050	½	0.93 (24)	0.375 (10)	1.56 (40)	2.41 (61)	1.25 (32)	75 (34)	20 (2.8)
OS-UB-075	¾	1.12 (28)	0.375 (10)	1.66 (42)	2.60 (66)	1.25 (32)	75 (34)	20 (2.8)
OS-UB-100	1	1.37 (35)	0.375 (10)	1.78 (45)	2.85 (72)	1.25 (32)	75 (34)	20 (2.8)
OS-UB-125	1¼	1.68 (43)	0.375 (10)	1.94 (49)	3.16 (80)	1.25 (32)	75 (34)	20 (2.8)
OS-UB-150	1½	2.00 (51)	0.375 (10)	2.10 (53)	3.47 (88)	1.25 (32)	75 (34)	20 (2.8)
OS-UB-200	2	2.43 (62)	0.500 (13)	2.46 (62)	4.18 (106)	1.50 (38)	150 (68)	40 (5.5)
OS-UB-250	2½	2.93 (74)	0.500 (13)	2.71 (69)	4.68 (119)	1.50 (38)	150 (68)	40 (5.5)
OS-UB-300	3	3.56 (90)	0.500 (13)	3.03 (77)	5.31 (135)	1.50 (38)	150 (68)	40 (5.5)
OS-UB-350	3½	4.06 (103)	0.500 (13)	3.28 (83)	5.81 (148)	1.50 (38)	150 (68)	40 (5.5)
OS-UB-400	4	4.56 (116)	0.500 (13)	3.53 (90)	6.31 (160)	1.50 (38)	150 (68)	40 (5.5)

## SUPPORT RACKS

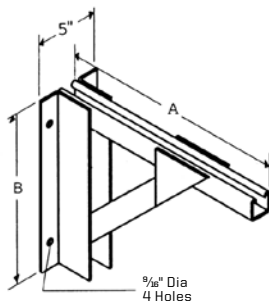

Part No.	Tray Width	Dimensions	
		A	B
OS-SR-06	6 (152)	10 (254)	10 (254)
OS-SR-09	9 (229)	13 (330)	12 (305)
OS-SR-12	12 (305)	16 (406)	13 (330)
OS-SR-18	18 (457)	22 (559)	16 (406)
OS-SR-24	24 (610)	28 (711)	19 (483)
OS-SR-30	30 (762)	34 (864)	22 (559)
OS-SR-36	36 (914)	40 (1016)	25 (635)

Allowable load = 750 lbs.- based on total load, uniformly distributed over the width of the rack. Safety factor = 2

## BEAM CLAMPS

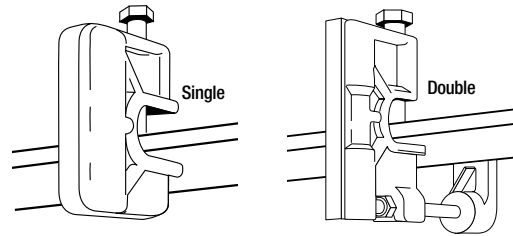

Part No.	Vinyl Ester Beam Clamps	
OS-BC-3/8	Single for ¾	FRP Threaded Rod
OS-BC-1/2	Single for ½	FRP Threaded Rod
OS-DC-3/8	Double for ¾	FRP Threaded Rod
OS-DC-1/2	Double for ½	FRP Threaded Rod

Allowable load = 300 lbs. Recommended safety factor of 3. Set screws included with clamps.

## FRP THREADED RODS

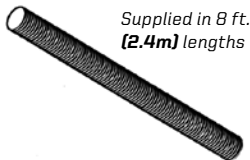

Part No.	Size
OS-TR-3/8	¾ - 16 UNC
OS-TR-1/2	½ - 13 UNC
OS-TR-5/8	¾ - 11 UNC
OS-TR-3/4	¾ - 10 UNC
OS-TR-1	1 - 8 UNC

## FRP CHANNEL NUTS & ROD COUPLERS



Part No.	Size
OS-CN- 3/8-V	¾ - 16 UNC
OS-CN- 1/2-V	½ - 13 UNC

Part No.	Size
OS-TR-3/8	¾ - 16 UNC
OS-TR-1/2	½ - 13 UNC
OS-TR-5/8	¾ - 11 UNC
OS-TR-3/4	¾ - 10 UNC
OS-TR-1	1 - 8 UNC

## FRP HEX NUTS & WASHERS



Part No.	Size
OS-TR-3/8	¾ - 16 UNC
OS-TR-1/2	½ - 13 UNC
OS-TR-5/8	¾ - 11 UNC
OS-TR-3/4	¾ - 10 UNC
OS-TR-1	1 - 8 UNC



Part No.	Size
OS-TR-3/8	¾ - 16 UNC
OS-TR-1/2	½ - 13 UNC
OS-TR-5/8	¾ - 11 UNC
OS-TR-3/4	¾ - 10 UNC
OS-TR-1	1 - 8 UNC

## GENERAL

- Conduit shall be fiberglass reinforced epoxy as manufactured by Champion Fiberglass, Inc. using the filament winding process.
- Conduit, elbows and fittings shall be manufactured from the same resin/hardener/glass systems manufactured by the same filament wound system.
- Conduit shall be integral bell and spigot.
- Conduit, elbows and fittings are specified for use throughout a temperature range of -60°F **(-51°C)** to 250°F **(121°C)**.
- Resin systems shall be epoxy with no fillers.
- Glass used shall be E-type.

## ELECTRICAL PROPERTIES

• Volume Resistivity	3.8 x 10 <sup>14</sup> ohm-cm	ASTM D 257
• Surface Resistivity	1.1 x 10 <sup>14</sup> ohms	ASTM D 257
• Dielectric Constant	3.5 (at 10 <sup>3</sup> cps)	ASTM D 150
• Dissipation Factor	0.005 (at 10 <sup>3</sup> cps)	ASTM D 150
• Dielectric Strength	500 volts/mil. <b>(19.7 kv/mm)</b>	ASTM D 149

## PHYSICAL AND MECHANICAL PROPERTIES

• Tensile Strength (Axial)	11,000 psi <b>(76 MPa)</b>	ASTM D 2105
• Compressive Strength (Axial)	12,000 psi <b>(83 MPa)</b>	ASTM D 695
• Ultimate Elongation	2% psi <b>(9.6 GPa)</b>	ASTM D 2105
• Modulus of Elasticity (4" conduit)	1.4 X 10 <sup>+6</sup> psi <b>(9.6 GPa)</b>	ASTM D 2105
• Thermal Conductivity	2.0 BTU/(ft <sup>2</sup> )(hr.)(°F/in) <b>(0.3 W/mk)</b>	ASTM D 5930-01
• Specific Gravity	1.9	ASTM D 792
• Glass Content	70% ± 5%	API SPEC 15 LR
• Water Absorption	Less than 1%	ASTM D 570
• Barcol Hardness	54 ± 2	ASTM D2583
• Flammability Above Ground Conduit	Conform to UL 1684 A	
• Coefficient of Thermal Expansion	1.2 x 10 <sup>-5</sup> in/in/°F <b>(2.2 10<sup>-5</sup> m/m/°C)</b>	ASTM D 696

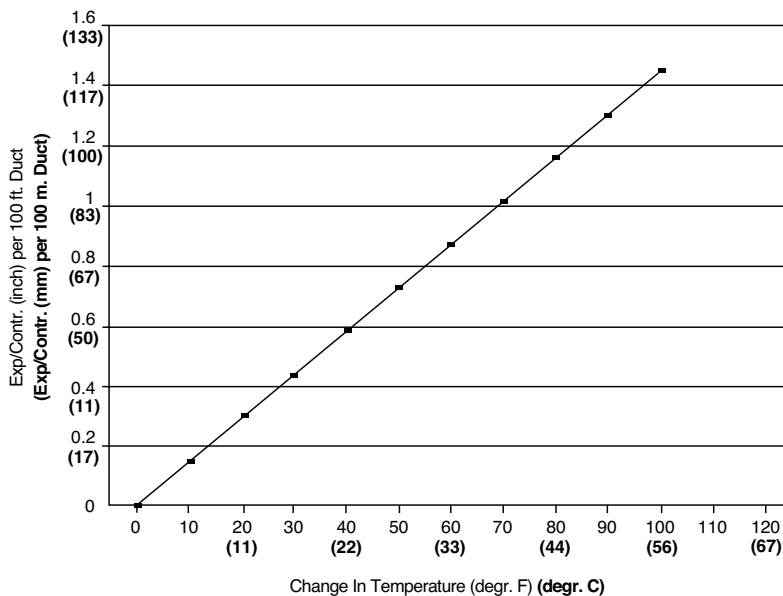

## HEAT DISTORTION

The minimum heat distortion temperature shall be 230°F (**110°C**) when tested at 264 psi in accordance with ASTM D 648.

## JOINT PULLOUT

A 12-inch length shall be cut from both the belled end and spigot end of a length of conduit. The two parts shall be assembled in accordance with Champion's instructions. The assembly shall be tested in accordance with ASTM D 2105 and shall meet the requirements of the table below.

Resistance Minimum Force - lbs (N)	
Nominal Size	Tight Lock Joints (Adhesive)
All	11,000 psi x (cross sectional area of conduit)

## TOXICITY

CHAMPION HAZ DUCT conduit does not contain any compounds that can release halogens - bromine or chlorine - when burning.

Gases	Values (max P.P.M.)
Hydrogen Chloride	0
Hydrogen Bromide	0
Hydrogen Cyanide	<1
Hydrogen Sulphide	0
Ammonia	0
Aldehydes as HCHO	<10
Oxides of Nitrogen	<50
Carbon Dioxide	<12,500
Carbon Monoxide	<250

## SURFACE FINISH

- Exterior Surface Normally less than 2,000 microinches (50.8 micron)
- Interior Surface Normally less than 125 microinches (3.2 micron)

## COLOR

Standard color is black, using carbon black as pigment. Optional colors are gray, red, orange and blue.

*Note: When ordering optional colors, the finished product may exhibit slight to extreme color variations.*

## WATER TIGHTNESS

There should be no evidence of water leakage through the joint when tested in accordance to UL 2515 and CSA C22.2 No. 2515. In order to achieve water tightness use CHAMPION MIX® or Epoxy Adhesive Kit for Tight Lock Joint. See page 22 of this catalog.

## IMPACT RESISTANCE

The minimum impact resistance values for the conduit shall be as shown in the table below when tested in accordance with ASTM D2444.

Nominal Size	At 73.4°F (23°C)	At 32°F (0°C)
	Impact Resistance lbs. ft. (Nm) XW	Impact Resistance lbs. ft. (Nm) XW
¾	150 (202)	150 (202)
1	400 (540)	400 (540)
1¼	400 (540)	400 (540)
1½	500 (675)	500 (675)
2	550 (742)	550 (742)
2½	600 (810)	600 (810)
3	700 (945)	700 (945)
3½	850 (1,150)	850 (1,150)
4	1,000 (1,350)	1,000 (1,350)
5	1,200 (1,620)	1,200 (1,620)
6	1,300 (1,755)	1,300 (1,755)

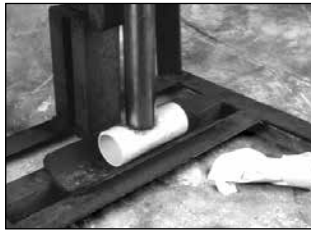

For high impact situations as well as during cold weather, PVC can shatter and/or flatten.

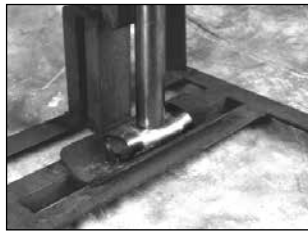

For high impact, steel conduit will collapse and can pinch the cable. This will make repair of damaged conduit more difficult.

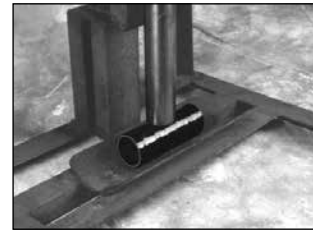

X-wall conduit has the highest impact value of all conduit materials available. If impacted, it will flex back close to its original diameter. SW, MW and HW will also flex back similarly after impact. They will not shatter.

## STIFFNESS

The minimum conduit stiffness at five percent deflection for all sizes of conduit shall not be less than the values given in table below when tested in accordance with ASTM D2412.

Pipe Stiffness (PS) = (F/ΔY)		
Nominal Size	At 73.4°F (23°C)	At 32°F (0°C)
	lbf/in <sup>2</sup> (MPa) XW	lbf/in <sup>2</sup> (MPa) XW
¾	2,500 (17.5)	2,500 (17.5)
1	2,400 (16.8)	2,400 (16.8)
1¼	2,100 (14.7)	2,100 (14.7)
1½	2,000 (14)	2,000 (14)
2	1,300 (9.0)	1,300 (9.0)
2½	800 (5.6)	800 (5.6)
3	600 (4.1)	600 (4.1)
3½	450 (3.1)	450 (3.1)
4	250 (1.7)	250 (1.7)
5	180 (1.2)	180 (1.2)
6	150 (1.0)	150 (1.0)

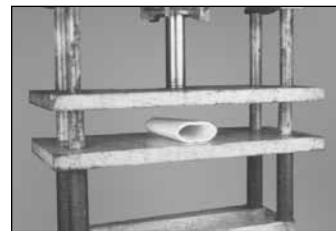

### PVC CONDUIT

PVC conduit will stay compressed if it is crushed. (Same for steel conduit.)

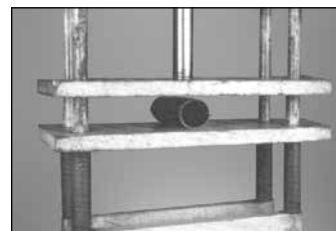

### FIBERGLASS CONDUIT

Champion Haz Duct conduit will flex back to almost its original shape after crushing.

## WIRE FILL

Maximum allowable percentage wire fill per Table 1, Chapter 9, National Electric Code 2008

XW Sizes							
Trade Size	Internal Diameter in (mm)	Total Area sq in (sq mm)	Percent of cross section of conduit & tubing for conductors				
			1 conductor		2 conductors		Over 2 conductors
			53% fill		31% fill		40% fill
			sq in (sq mm)	sq in (sq mm)	sq in (sq mm)	sq in (sq mm)	
¾ (19)	0.910 (23)	0.650 (419)	0.345 (222)	0.202 (130)	0.260 (168)		
1 (25)	1.175 (30)	1.084 (697)	0.575 (369)	0.336 (216)	0.434 (279)		
1¼ (32)	1.520 (39)	1.815 (1170)	0.962 (620)	0.563 (363)	0.726 (468)		
1½ (38)	1.760 (45)	2.433 (1569)	1.289 (832)	0.754 (486)	0.973 (628)		
2 (51)	2.000 (51)	3.142 (2027)	1.665 (1074)	0.974 (628)	1.257 (811)		
2½ (64)	2.500 (64)	4.909 (3167)	2.602 (1679)	1.522 (982)	1.964 (1267)		
3 (76)	3.000 (76)	7.069 (4560)	3.747 (2417)	2.191 (1414)	2.828 (1824)		
3½ (89)	3.500 (89)	9.621 (6207)	5.099 (3290)	2.983 (1924)	3.848 (2483)		
4 (102)	4.000 (102)	12.566 (8107)	6.660 (4297)	3.895 (2513)	5.026 (3243)		
5 (127)	5.000 (127)	19.635 (12668)	10.407 (6714)	6.087 (3927)	7.854 (5067)		
6 (152)	6.000 (152)	28.274 (18241)	14.985 (9668)	8.765 (5655)	11.3010 (7296)		

## COEFFICIENT OF FRICTION

The following data for static coefficient of friction is for dry conduit and non-lubricated cable at a temperature of 72° F [22° C].

Cable Material	Conduit Material					
	Epoxy Fiberglass Conduit	PVC Conduit	Steel Conduit	Aluminum Conduit	Concrete Conduit	Polyethylene Conduit
PVC	.38	.90	.55	.25	.95	1.90
XLP (Cross-linked Polyethylene)	.23	.90	.75	1.50	.75	2.00
LDPE (Polyethylene)	.25	.50	.50	.62	.60	1.70
Neoprene	.53	2.60	1.60	.26	1.35	3.30
Concentric Neutral	.16	--	--	--	--	--
Tech (Armored) Cable	.16	2.60	1.60	.26	1.35	3.30

## CORROSION RESISTANCE GUIDE

The corrosion guidelines tests were performed by immersing epoxy coupons for 30 days in the chemical at the temperature shown. This is a very severe test. It has been shown that **CHAMPION HAZ DUCT®** can often be used for chemicals listed as “Not Recommended” (NR). Real cases often are limited to fumes, vapors and occasional splashes at the temperatures indicated.

This information is provided solely as a guide since it is impossible to anticipate all individual site conditions. For specific applications which are not covered in this guide, and may require screening tests to evaluate resin system suitability, consultation with Champion Fiberglass, Inc. is recommended.

Chemical	°F	°C	Chemical	°F	°C
Acetic Acid 15%	175	<b>79</b>	Lactic Acid	150	<b>66</b>
Acetic Acid 50%	NR	<b>NR</b>	Lime Slurry, Sat'd	100	<b>38</b>
Acetic Acid (Glacial)	NR	<b>NR</b>	Magnesium Salts	150	<b>66</b>
Acetone	NR	<b>NR</b>	Methyl Alcohol, 10%	100	<b>38</b>
Aluminum Chloride, 1%	200	<b>93</b>	Methyl Ethyl Ketone, 100%	NR	<b>NR</b>
Aluminum Hydroxide 30%	NR	<b>NR</b>	Mineral Oils	200	<b>93</b>
Aluminum Sulphate, 25%	150	<b>66</b>	Naphtha	100	<b>38</b>
Ammonium Chloride, Sat'd	150	<b>66</b>	Nickel Salts	100	<b>38</b>
Ammonium Hydroxide 20%	NR	<b>NR</b>	Nitric Acid	NR	<b>NR</b>
Ammonium Nitrate, Sat'd	150	<b>66</b>	Oleic Acid	150	<b>66</b>
Ammonium Sulfate, Sat'd	150	<b>66</b>	Oxalic Acid	150	<b>66</b>
Benzene, 10%	70	<b>21</b>	Perchloroethylene	70	<b>21</b>
Benzene Sulfonic Acid 30%	NR	<b>NR</b>	Phenol, 0-2%	75	<b>24</b>
Benzoic Acid, Sat'd	140	<b>60</b>	Phosphoric Acid, 10%	125	<b>52</b>
Calcium Salts	150	<b>66</b>	Potassium Carbonate, 0-15%	NR	<b>NR</b>
Carbon Dioxide	150	<b>66</b>	Potassium Permanganate, 5%	75	<b>24</b>
Carbon Tetrachloride	NR	<b>NR</b>	Potassium Sulfate, 10%	100	<b>38</b>
Chlorine, Wet Gas	NR	<b>NR</b>	Sodium Bicarbonate	125	<b>52</b>
Chlorine Water	150	<b>66</b>	Sodium Bisulfate	180	<b>82</b>
Chlorobenzene	NR	<b>NR</b>	Sodium Carbonate, 10%	75	<b>24</b>
Citric Acid, Sat'd	150	<b>66</b>	Sodium Chloride	200	<b>93</b>
Diesel Fuel	150	<b>66</b>	Sodium Dichromate	75	<b>24</b>
Ethyl Alcohol	75	<b>24</b>	Sodium Hydroxide, 1%	75	<b>24</b>
Ethylene Glycol	190	<b>88</b>	Sodium Hypochlorite	NR	<b>NR</b>
Ferrous Sulfate	150	<b>66</b>	Sodium Nitrate	100	<b>38</b>
Fuel Oil	150	<b>66</b>	Sodium Sulfate, 10%	100	<b>38</b>
Gasoline	140	<b>60</b>	Sodium Sulfide, 10%	75	<b>24</b>
Glycerine	200	<b>93</b>	Sodium Thiosulfate	NR	<b>NR</b>
Hydrochloric Acid 0-10%	125	<b>52</b>	Styrene	NR	<b>NR</b>
Hydrochloric Acid 10-36%	NR	<b>NR</b>	Sulfur Dioxide, Dry or Wet Gas	150	<b>66</b>
Hydrofluoric Acid	NR	<b>NE</b>	Sulfuric Acid, Vapor	100	<b>38</b>
Hydrogen Chloride, Dry or Wet Gas	100	<b>38</b>	Tannic Acid, 15%	150	<b>66</b>
Hydrogen Peroxide	NR	<b>NR</b>	Tartaric Acid	150	<b>66</b>
Hydrogen Sulfide, Dry or Wet Gas	125	<b>52</b>	Toluene	NR	<b>NR</b>
Kerosene	150	<b>66</b>	Water, City	170	<b>77</b>

**NR = Not Recommended**

Information in this table is based on data supplied by raw material suppliers and collected from many years of similar industrial applications.

Temperatures represent standard test conditions and are not minimums or maximums. **CHAMPION HAZ DUCT®** products may be acceptable at other temperatures for some chemicals, but should be tested to determine specific suitability.

The recommendations or suggestions contained in this table are made without guarantee or representation as to results. We suggest that you evaluate these recommendations and suggestions in your own laboratory or field trial prior to use.



## SEALING FITTINGS FOR FIBERGLASS CONDUIT TRANSITIONS

Every time the conduit transitions from a Class I Division 1, area to a Class I Division 2, area or when it leaves a Class I Division 2 area and passes to a nonhazardous location seals must be used.

Sealing fittings are made by other manufacturers in metallic materials. Contact Champion Fiberglass, Inc. for further information.



*Vertical Female*



*Vertical Male & Female*



*Vertical or Horizontal Female*



*Vertical or Horizontal Male & Female*

### LOCATION OF SEALS

#### Class I Div 1 to Class I Div 2

When transitioning from Class I Division 1 to Class I Division 2, seals shall be located on the Class I Division 2 side. The seal must be within 3.05m (10ft.) of the boundary between the two sides.

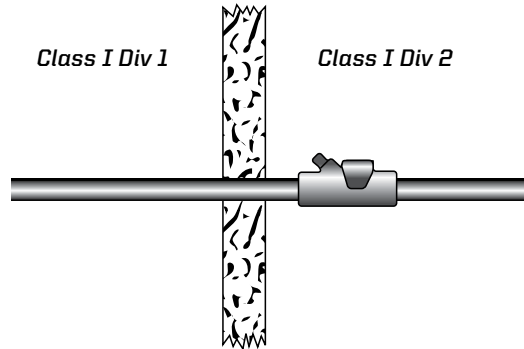

#### Class I Div 2 to Nonhazardous Area

When leaving a Class I Division 2 area and going into a non-hazardous area, there shall be a sealing fitting. The sealing fitting should be located within 3.05m (10 ft.) on the non-hazardous side of the boundary.

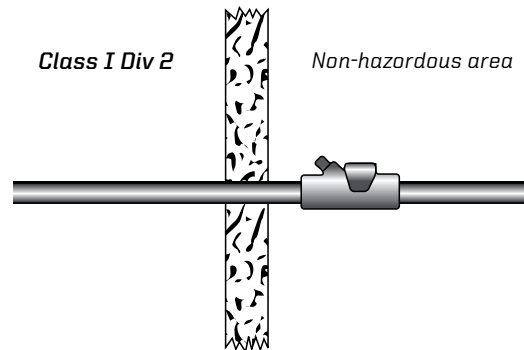

## EXCERPT - SEALING FITTINGS, NEC (2008)

(Copyright 2007 NFPA)

### Per the 2008 National Electrical Code, in a Class I Division 2 location, article 501.15, Sealing and Drainage

- (B) **Conduit Seals, Class I, Division 2.** In Class I, Division 2 locations, conduit seals shall be located in accordance with 501.15(B)(1) and (B)(2).
- (1) **Entering Enclosures.** For connections to enclosures that are required to be explosionproof, a conduit seal shall be provided in accordance with 501.15(A)(1)(1) and (A)(3). All portions of the conduit run or nipple between the seal and such enclosure shall comply with 501.10(A).
- (2) **Class I, Division 2 Boundary.** In each conduit run passing from a Class I, Division 2 location into an unclassified location. The sealing fitting shall be permitted on either side of the boundary of such location within 3.05 m (10 ft) of the boundary. Rigid metal conduit or threaded steel intermediate metal conduit shall be used between the sealing fitting and the point at which the conduit leaves the Division 2 location, and a threaded connection shall be used at the sealing fitting. Except for listed reducers at the conduit seal, there shall be no union, coupling, box, or fitting between the conduit seal and the point at which the conduit leaves the Division 2 location. Conduits shall be sealed to minimize the amount of gas or vapor within the Division 2 portion of the conduit from being communicated to the conduit beyond the seal. Such seals shall not be required to be explosionproof but shall be identified for the purpose of minimizing passage of gases under normal operating conditions and shall be accessible.
- Exception No. 1:** Metal conduit that contains no unions, couplings, boxes, or fittings, and passes completely through a Class I, Division 2 location with no fittings less than 300 mm (12 in.) beyond each boundary, shall not be required to be sealed if the termination points of the unbroken conduit are in unclassified locations.
- Exception No. 2:** Conduit systems terminating at an unclassified location where a wiring method transition is made to cable tray, cablebus, ventilated busway, Type MI cable, or cable not installed in any cable tray or raceway system shall not be required to be sealed where passing from the Class I, Division 2 location into the unclassified location. The unclassified location shall be outdoors or, if the conduit system is all in one room, it shall be permitted to be indoors. The conduits shall not terminate at an enclosure containing an ignition source in normal operation.
- Exception No. 3:** Conduit systems passing from an enclosure or room that is unclassified as a result of pressurization into a Class I, Division 2 location shall not require a seal at the boundary.
- FPN: For further information, refer to NFPA 496-2003, Standard for Purged and Pressurized Enclosures for Electrical Equipment.
- Exception No. 4:** Segments of aboveground conduit systems shall not be required to be sealed where passing from a Class I, Division 2 location into an unclassified location if all of the following conditions are met:
- (1) No part of the conduit system segment passes through a Class I, Division 1 location where the conduit contains unions, couplings, boxes, or fittings within 300 mm (12 in.) of the Class I, Division 1 location.
  - (2) The conduit system segment is located entirely in outdoor locations.
  - (3) The conduit system segment is not directly connected to canned pumps, process or service connections for flow, pressure, or analysis measurement, and so forth, that depend on a single compression seal, diaphragm, or tube to prevent flammable or combustible fluids from entering the conduit system.
  - (4) The conduit system segment contains only threaded metal conduit, unions, couplings, conduit bodies, and fittings in the unclassified location.
  - (5) The conduit system segment is sealed at its entry to each enclosure or fitting housing terminals, splices, or taps in Class I, Division 2 locations.
- (C) **Class I, Divisions 1 and 2.** Seals installed in Class I, Division 1 and Division 2 locations shall comply with 501.15(C)(1) through (C)(6). **Exception:** Seals not required to be explosionproof by 501.15(B)(2) or 504.70.
- (1) **Fittings.** Enclosures for connections or equipment shall be provided with an integral means for sealing, or sealing fittings listed for the location shall be used. Sealing fittings shall be listed for use with one or more specific compounds and shall be accessible.
  - (2) **Compound.** The compound shall provide a seal against passage of gas or vapors through the seal fitting, shall not be affected by the surrounding atmosphere or liquids, and shall not have a melting point of less than 93°C (200°F).
  - (3) **Thickness of Compounds.** Except for listed cable sealing fittings, the thickness of the sealing compound in a completed seal shall not be less than the metric designator (trade size) of the sealing fitting expressed in the units of measurement employed, and in no case less than 16 mm (5/8 in.).
  - (4) **Splices and Taps.** Splices and taps shall not be made in fittings intended only for sealing with compound, nor shall other fittings in which splices or taps are made be filled with compound.
  - (5) **Assemblies.** In an assembly where equipment that may produce arcs, sparks, or high temperatures is located in a compartment separate from the compartment containing splices or taps, and an integral seal is provided where conductors pass from one compartment to the other, the entire assembly shall be identified for the location. Seals in conduit connections to the compartment containing splices or taps shall be provided in Class I, Division 1 locations where required by 501.15(A)(1)(2).
  - (6) **Conductor Fill.** The cross-sectional area of the conductors permitted in a seal shall not exceed 25 percent of the cross-sectional area of a rigid metal conduit of the same trade size unless it is specifically identified for a higher percentage of fill.

## EXCERPT - SEALING FITTINGS, NEC (2008)

(Copyright 2007 NFPA)

### Furthermore, in a Class I Zone 2 location, article 505.16, Sealing and Drainage

- (C) **Zone 2.** In Class I, Zone 2 locations, seals shall be located in accordance with 505.16(C)(1) and (C)(2).
- (1) **Conduit Seals.** Conduit seals shall be located in accordance with (C)(1)(a) and (C)(1)(b).
- (a) For connections to enclosures that are required to be flameproof or explosionproof, a conduit seal shall be provided in accordance with 505.16(B)(1) and (B)(2). All portions of the conduit run or nipple between the seal and such enclosure shall comply with 505.16(B).
- (b) In each conduit run passing from a Class I, Zone 2 location into an unclassified location. The sealing fitting shall be permitted on either side of the boundary of such location within 3.05 m (10 ft) of the boundary and shall be designed and installed so as to minimize the amount of gas or vapor within the Zone 2 portion of the conduit from being communicated to the conduit beyond the seal. Rigid metal conduit or threaded steel intermediate metal conduit shall be used between the sealing fitting and the point at which the conduit leaves the Zone 2 location, and a threaded connection shall be used at the sealing fitting. Except for listed explosionproof reducers at the conduit seal, there shall be no union, coupling, box, or fitting between the conduit seal and the point at which the conduit leaves the Zone 2 location.

**Exception No. 1:** Metal conduit containing no unions, couplings, boxes, or fittings and passing completely through a Class I, Zone 2 location with no fittings less than 300 mm (12 in.) beyond each boundary shall not be required to be sealed if the termination points of the unbroken conduit are in unclassified locations.

**Exception No. 2:** Conduit systems terminating at an unclassified location where a wiring method transition is made to cable tray, cablebus, ventilated busway, Type MI cable, or cable that is not installed in a raceway or cable tray system shall not be required to be sealed where passing from the Class I, Zone 2 location into the unclassified location. The unclassified location shall be outdoors or, if the conduit system is all in one room, it shall be permitted to be indoors. The conduits shall not terminate at an enclosure containing an ignition source in normal operation.

**Exception No. 3:** Conduit systems passing from an enclosure or room that is unclassified as a result of pressurization into a Class I, Zone 2 location shall not require a seal at the boundary.

FPN: For further information, refer to NFPA 496-2003, Standard for Purged and Pressurized Enclosures for Electrical Equipment.

**Exception No. 4:** Segments of aboveground conduit systems shall not be required to be sealed where passing from a Class I, Zone 2 location into an unclassified location if all the following conditions are met:

- (1) No part of the conduit system segment passes through a Class I, Zone 0 or Class I, Zone 1 location where the conduit contains unions, couplings, boxes, or fittings within 300 mm (12 in.) of the Class I, Zone 0 or Class I, Zone 1 location.
- (2) The conduit system segment is located entirely in outdoor locations.
- (3) The conduit system segment is not directly connected to canned pumps, process or service connections for flow, pressure, or analysis measurement, and so forth, that depend on a single compression seal, diaphragm, or tube to prevent flammable or combustible fluids from entering the conduit system.

- (4) The conduit system segment contains only threaded metal conduit, unions, couplings, conduit bodies, and fittings in the unclassified location.
- (5) The conduit system segment is sealed at its entry to each enclosure or fitting housing terminals, splices, or taps in Class I, Zone 2 locations.
- (2) **Cable Seals.** Cable seals shall be located in accordance with (C)(2)(a), (C)(2)(b), and (C)(2)(c).
  - (a) Explosionproof and Flameproof Enclosures. Cables entering enclosures required to be flameproof or explosionproof shall be sealed at the point of entrance. The seal shall comply with 505.16(D). Multiconductor cables with a gas/vaportight continuous sheath capable of transmitting gases or vapors through the cable core shall be sealed in the Zone 2 location after removing the jacket and any other coverings so that the sealing compound surrounds each individual insulated conductor in such a manner as to minimize the passage of gases and vapors. Multiconductor cables in conduit shall be sealed as described in 505.16(B)(4).

**Exception No. 1:** Cables passing from an enclosure or room that is unclassified as a result of Type Z pressurization into a Class I, Zone 2 location shall not require a seal at the boundary.

**Exception No. 2:** Shielded cables and twisted pair cables shall not require the removal of the shielding material or separation of the twisted pairs, provided the termination is by an approved means to minimize the entrance of gases or vapors and prevent propagation of flame into the cable core.

- (b) **Cables That Will Not Transmit Gases or Vapors.** Cables with a gas/vaportight continuous sheath and that will not transmit gases or vapors through the cable core in excess of the quantity permitted for seal fittings shall not be required to be sealed except as required in 505.16(C)(2)(a). The minimum length of such cable run shall not be less than the length that limits gas or vapor flow through the cable core to the rate permitted for seal fittings [200 cm<sup>3</sup>/hr (0.007 ft<sup>3</sup>/hr) of air at a pressure of 1500 pascals (6 in. of water)].

FPN No. 1: For further information on construction, testing, and marking requirements for conduit sealing fittings, see ANSI/UL 1203, Explosionproof and Dust-Ignition-Proof Electrical Equipment for Use in Hazardous (Classified) Locations.

FPN No. 2: The cable core does not include the interstices of the conductor strands.

- (c) **Cables Capable of Transmitting Gases or Vapors.** Cables with a gas/vaportight continuous sheath capable of transmitting gases or vapors through the cable core shall not be required to be sealed except as required in 505.16(C)(2)(a), unless the cable is attached to process equipment or devices that may cause a pressure in excess of 1500 pascals (6 in. of water) to be exerted at a cable end, in which case a seal, barrier, or other means shall be provided to prevent migration of flammables into an unclassified area.

**Exception:** Cables with an unbroken gas/vaportight continuous sheath shall be permitted to pass through a Class I, Zone 2 location without seals.

- (d) **Cables Without Gas/Vaportight Continuous Sheath.** Cables that do not have gas/vaportight continuous sheath shall be sealed at the boundary of the Zone 2 and unclassified location in such a manner as to minimize the passage of gases or vapors into an unclassified location.

FPN: The cable sheath may be either metal or a nonmetallic material.

# NATIONAL ELECTRICAL CODE, NEC (2008)

(Copyright 2007 NFPA)

Article 355 - Reinforced Thermosetting Resin Conduit Type (RTRC)

## I. General

### 355.1 Scope.

This article covers the use, installation, and construction specification for reinforced thermosetting resin conduit (RTRC) and associated fittings.

FPN: Refer to Article 352 for Rigid Polyvinyl Chloride Conduit: Type PVC, and Article 353 for High Density Polyethylene Conduit: Type HDPE.

### 355.2 Definition.

**Reinforced Thermosetting Resin Conduit (RTRC).** A rigid nonmetallic conduit (RNC) of circular cross section, with integral or associated couplings, connectors, and fittings for the installation of electrical conductors and cables.

### 355.6 Listing Requirements.

RTRC, factory elbows, and associated fittings shall be listed.

## II. Installation

### 355.10 Uses Permitted.

The use of RTRC shall be permitted in accordance with 355.10 (A) through (H).

- (A) **Concealed.** RTRC shall be permitted in walls, floors, and ceilings.
- (B) **Corrosive Influences.** RTRC shall be permitted in locations subject to severe corrosive influences as covered in 300.6 and where subject to chemicals for which the materials are specifically approved.
- (C) **Cinders.** RTRC shall be permitted in cinder fill.
- (D) **Wet Locations.** RTRC shall be permitted in portions of dairies, laundries, canneries, or other wet locations and in locations where walls are frequently washed, the entire conduit system, including boxes and fittings used therewith, shall be installed and equipped so as to prevent water from entering the conduit. All supports, bolts, straps, screws, and so forth, shall be of corrosion-resistant materials or be protected against corrosion by approved corrosion-resistant materials.
- (E) **Dry and Damp Locations.** RTRC shall be permitted for use in dry and damp locations not prohibited by 355.12.
- (F) **Exposed.** RTRC shall be permitted for exposed work where not subject to physical damage if identified for such use.
- (G) **Underground Installations.** For underground installations, see 300.5 and 300.50.
- (H) **Support of Conduit Bodies.** RTRC shall be permitted to support nonmetallic conduit bodies not larger than the largest trade size of an entering raceway. These conduit bodies shall not support luminaires or other equipment and shall not contain devices other than splicing devices as permitted by 110.14(B) and 314.16(C)(2).

### 355.12 Uses Not Permitted.

RTRC shall not be used under the following conditions.

- (A) **Hazardous (Classified) Locations.**
  1. In any hazardous (classified) location, except as permitted by other articles in this *Code*
  2. In class I, Division 2 locations, except as permitted in 501.10(B)(3)

- (B) **Support of Luminaries.** For the support of luminaries or other equipment not described in 355.10(H).
- (C) **Physical Damage.** Where subject to physical damage unless identified for such use.\*
- (D) **Ambient Temperatures.** Where subject to ambient temperatures in excess of 50°C (122°F) unless listed otherwise.\*\*
- (E) **Insulation Temperature Limitations.** For conductors or cables operating at temperature higher than the RTRC listed operating temperature rating.

**Exception:** Conductors of cables rated at a temperature higher than the RTRC listed temperature rating shall be permitted to be installed in RTRC, provided they are not operated at a temperature higher than the RTRC listed temperature rating.

- (F) **Theaters and Similar Locations.** In theaters and similar locations, except as provided in Articles 518.4 and 520.5.

(\* *Champion Haz Duct® is identified for such use, i.e. can be used where Physical Damage is of concern.*

(\*\* *Champion Haz Duct® is listed for 110°C (230°F).*

## Article / 501.10

### (B) Class I, Division 2

- (1) **General.** In Class I, Division 2 locations, the following wiring methods shall be permitted. (*excerpt below*)
- (7) In industrial establishments with restricted public access where the conditions of maintenance and supervision ensure that only qualified persons service the installation and where metallic conduit does not provide sufficient corrosion resistance, reinforced thermosetting resin conduit (RTRC), factory elbows, and associated fittings, all marked with the suffix -XW, and Schedule 80 PVC conduit, factory elbows, and associated fittings shall be permitted. Where seals are required for boundary conditions as defined in 501.15(A)(4), the Division 1 wiring method shall extend into the Division 2 area to the seal, which shall be located on the Division 2 side of the Division 1-Division 2 boundary.

## Article / 505.15

### (C) Class I, Zone 2

- (1) **General.** In Class I, Zone 2 locations, the wiring methods in (C)(1)(a) through (C)(1)(h) shall be permitted. (*excerpt below*)
- (g) In industrial establishments with restricted public access where the conditions of maintenance and supervision ensure that only qualified persons service the installation and where metallic conduit does not provide sufficient corrosion resistance, reinforced thermosetting resin conduit (RTRC), factory elbows, and associated fittings, all marked with the suffix -XW, and Schedule 80 PVC conduit, factory elbows, and associated fittings shall be permitted. Where seals are required for boundary conditions as defined in 505.16(C)(1)(b), the Zone 1 wiring method shall extend into the Zone 2 area to the seal, which shall be located on the Zone 2 side of the Zone 1-Zone 2 boundary.

## LIMITED WARRANTY

This warranty covers any Champion Fiberglass, Inc. ("Champion") electrical conduit products ("Product").

Subject to the terms and conditions of this warranty, Champion warrants that the Product is free from defects in workmanship and materials for a period of one (1) year from the date of purchase. During the applicable terms of this warranty, and subject to the terms and conditions thereof, in the event that the Product is proven to be defective and the defect is not caused by any misuse or damage to the Product while in the possession of the user, Champion will remedy the failure or defect without charge to the user except for labor. The remedy will consist of repair or replacement of the Product and or defective part, at Champion's option. Repair will be made, at Champion's option, either at user's location or at a facility designated by Champion. Any replacement part provided under this warranty assumed as its warranty period only the unexpired term of this warranty, which is fixed when such part replaces a defective part. This warranty does not cover defects, failure or damages caused by normal wear and tear, act of God, accident, misuse or unreasonable use of the Product, lack of proper maintenance, fire, flood, or any circumstances or events beyond Champion's control.

Champion's sole obligation under this warranty is to repair or replace the product, as provided herein. Champion shall have no liability for any direct, incidental, special or consequential damages resulting from breach of this or any other warranty (no warranty being implied from this reference) on the product. Except to the extent prohibited by applicable law, any implied warranty, including without limitation, of merchantability or fitness for any particular purchase with respect to the product, is limited in duration to the term of this warranty. This warranty is in lieu of any other express warranties and of any other obligation on the part of Champion. Any other express warranties are expressly excluded and disclaimed. No Champion representative is authorized to give any warranty (other than this warranty) with respect to the product, and any such warranty given by a Champion representative shall not constitute a Champion warranty or be binding in any respect upon Champion.

Note: Some states do not allow the exclusion or limitation of incidental or consequential damages, so the above limitation or exclusion may not apply to you. Some states do not allow limitation on how long an implied warranty lasts, so the above limitations may not apply to you.

To obtain performance of any obligation of Champion under this warranty, the user must provide proof of the date of purchase, notify Champion of any warranty claim at the following address:

**CHAMPION FIBERGLASS, INC.**  
6400 Spring Stuebner Rd  
Spring, TX 77389  
Attention: Warranty Claims  
Telephone: (281) 655-8900

Notify the nearest Champion authorized representative for inspection of the Product. For the name of the nearest authorized representative, refer to our web site: [www.championfiberglass.com](http://www.championfiberglass.com) / Locate a Rep Tab / or you can contact our corporate offices for the appropriate Representative's contact information. Any written correspondence can be mailed to our corporate offices at the address above.

**This warranty gives you specific legal rights, and you may also have other rights which vary from state to state.**



# CERTIFICATE OF REGISTRATION

This is to certify that

## **Champion Fiberglass Inc.**

6400 Spring Stuebner Rd., Spring, Texas 77389 USA

operates a

## **Quality Management System**

which complies with the requirements of

## **ISO 9001:2008**

for the following scope of registration

### **Manufacture of fiberglass conduit and fittings.**

Certificate No.:	CERT-0065909	Original Certification Date:	November 6, 2009
File No.:	1058413	Current Certification Date:	November 5, 2012
Issue Date:	September 28, 2012	Certificate Expiry Date:	November 4, 2015

Chris Jouppi  
President,  
QMI-SAI Canada Limited

Guillaume Gignac, ing.f  
Vice President, Corporate Operations, Accreditation & Quality  
QMI-SAI Canada Limited



ISO 9001



Registered by:  
SAI Global Certification Services Pty Ltd, 286 Sussex Street, Sydney NSW 2000 Australia with QMI-SAI Canada Limited, 20 Carlson Court, Suite 200,  
Toronto, Ontario M9W 7K6 Canada (SAI GLOBAL). This registration is subject to the SAI Global Terms and Conditions for Certification. While all due care  
and skill was exercised in carrying out this assessment, SAI Global accepts responsibility only for proven negligence. This certificate remains the property  
of SAI Global and must be returned to them upon request.  
To verify that this certificate is current, please refer to the SAI Global On-Line Certification Register: [www.qmi-saiglobal.com/qmi\\_companies/](http://www.qmi-saiglobal.com/qmi_companies/)



▶ 6400 Spring Stuebner Rd  
Spring, TX 77389  
Main: 281.655.8900  
Fax: 281.257.2523

» [championfiberglass.com](http://championfiberglass.com)



© 2014 by Champion Fiberglass, Inc.  
All rights reserved. This catalog, or parts thereof, may not be reproduced  
in any other format without written permission of the publishers.